

# 1095

## FRESA SAGOMATA PER BASTONCINI ZIGRINATI SERRATED DOWELS PROFILE CUTTER

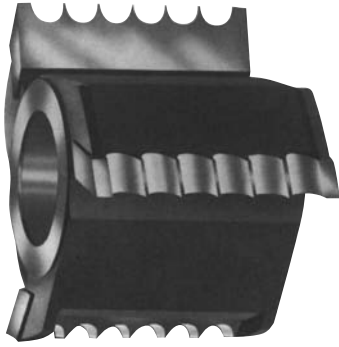

### APPLICAZIONE/APPLICATION:

Per la realizzazione contemporanea di più bastoncini zigrinati  
For cutting serrated dowels.

### MACCHINA/MACHINE:

Scorniatrici./Moulders

### INFORMAZIONI TECNICHE/TECHNICAL INFORMATION:

Impiego a coppie • Nr. giri ottimale fino ad un avanzamento di 15 mt./min.  $n = 6.000 \text{ min}^{-1}$

• Codice fresa = ART. + D + B

• Esempio: fresa D. 120 per realizzare 6 bastoncini d. 8 zigrinati - Codice 1095.120.061

Use in pairs • Optimal RPM  $n = 6.000 \text{ min}^{-1}$  up to a feed rate of 15 m min<sup>-1</sup>

• Cutter code = ART. + D + B

• Example = Cutter D. 120 to obtain 6 serrated dowels d.8 - Code = 1095.120.061

**HW** **Z=3** **MEC** Avanzamento meccanico  
Mechanical feed

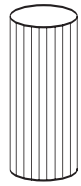

	Diam. bastoncino/Dowel diam.	DB	6	8	10	12	14	16	18	20
<b>Dentello/Spl. point</b>	S	1	1	1	1,5	1,5	1,5	1,5	1,5	2
<b>Passo/Pitch</b>	T	7	9	11	13,5	15,5	17,5	19,5	22	
<b>Ras. esterno/Square end</b>	P	4	4	5	5	5	5	5	5	7
<b>Diam. fresa/Cutter diameter</b>	D	120	120	120	120	120	140	140	140	
<b>2</b>	<b>Spess. fresa/Thickness</b>	B	21	25	31	33	40	44	48	56
	<b>Cod. prezzo/Price code</b>		G26	D27	H27	G28	A29	C30	M30	H31
<b>3</b>	<b>Spess. fresa/Thickness</b>	B	28	34	42	49	55	61	67	78
	<b>Cod. prezzo/Price code</b>		H27	G28	F29	H30	B31	D32	B33	L33
<b>4</b>	<b>Spess. fresa/Thickness</b>	B	35	43	53	63	71	79	87	100
	<b>Cod. prezzo/Price code</b>		E29	C30	B31	A32	A33	A34	L34	F35
<b>5</b>	<b>Spess. fresa/Thickness</b>	B	42	52	64	76	86	96	106	122
	<b>Cod. prezzo/Price code</b>		E30	C31	F32	F33	A34	C35	C36	M36
<b>6</b>	<b>Spess. fresa/Thickness</b>	B	49	61	75	90	102	114	126	144
	<b>Cod. prezzo/Price code</b>		B31	F32	D33	F34	B35	C36	M36	G37
<b>7</b>	<b>Spess. fresa/Thickness</b>	B	56	70	86	103	117	131	145	
	<b>Cod. prezzo/Price code</b>		F32	F33	C34	E35	C36	M36	G37	
<b>8</b>	<b>Spess. fresa/Thickness</b>	B	63	79	97	117	133	149		
	<b>Cod. prezzo/Price code</b>		A33	A34	M34	L35	G36	M37		
<b>9</b>	<b>Spess. fresa/Thickness</b>	B	70	88	108					
	<b>Cod. prezzo/Price code</b>		G33	D34	E35					
<b>10</b>	<b>Spess. fresa/Thickness</b>	B	77	97	119					
	<b>Cod. prezzo/Price code</b>		C34	B35	C36					

