

1375

FRESE PER QUARTI DI TONDO CUTTER FOR QUARTER ROUND



APPLICAZIONE/APPLICATION:

Fresa sagomata per quarti di tondo / Profile cutter for quarter round.

MACCHINA/MACHINE:

Toupie e scorniciatrici, squadatrici
Spindle shapers, moulders and double-end tenoners.

INFORMAZIONI TECNICHE/TECHNICAL INFORMATION:

Esecuzione con 4 taglianti assialmente inclinati • Foro "d" da 30 a 50 mm.
Designed with 4 shear cuts • Bore "d" from 30 to 50 mm.

D. 140 - n. 5.500-9.400 min⁻¹

D. 160 - n. 4.800-8.200 min⁻¹

D. 180 - n. 4.500-7.700 min⁻¹

HW

Z=4

MAN

Avanzamento manuale
Manual feed

MEC

Avanzamento meccanico
Mechanical feed

Codice Code	D D	B B	R R	Cod. Prezzo Price Code
1375.140.010	140	10	5	F19
1375.140.013	140	13	7,5	H19
1375.140.015	140	15	10	M19
1375.140.018	140	18	12,5	A20
1375.140.020	140	20	15	F20
1375.140.025	140	25	20	A21
1375.160.030	160	30	25	D22
1375.160.035	160	35	30	A23
1375.180.040	180	40	35	A26
1375.180.045	180	45	40	G26

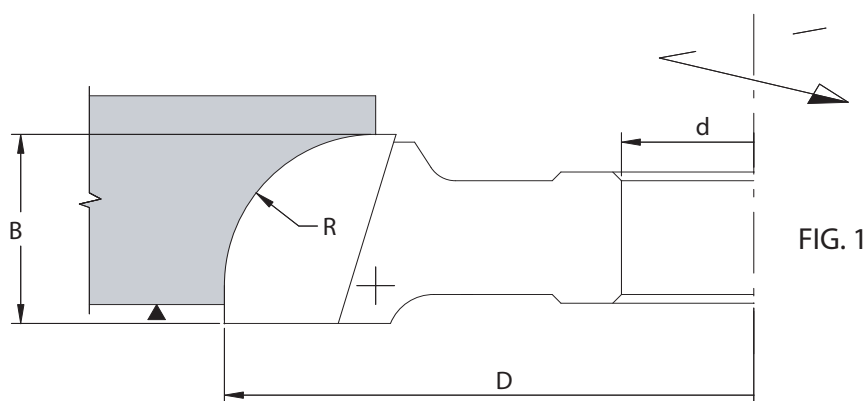

FIG. 1

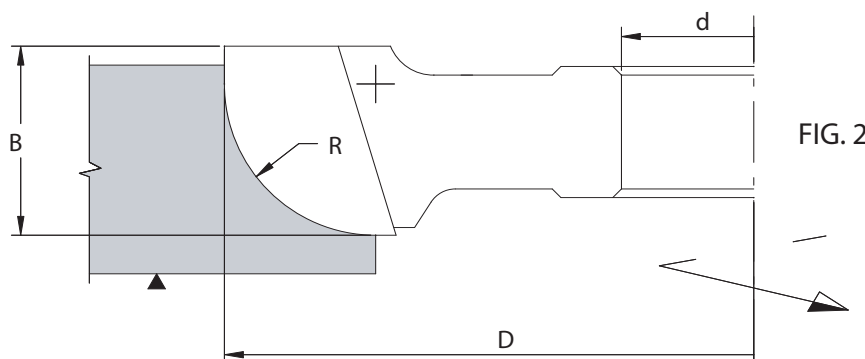

FIG. 2