

2276

TESTE PORTA COLTELLI PER BORDATRICI "BIESSE" CUTTERHEADS FOR BIESSE EDGEBANDING MACHINES

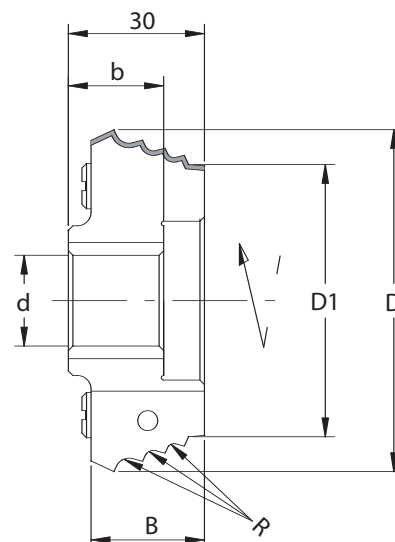

HW **Z=4** **MEC** Avanzamento meccanico
Mechanical feed

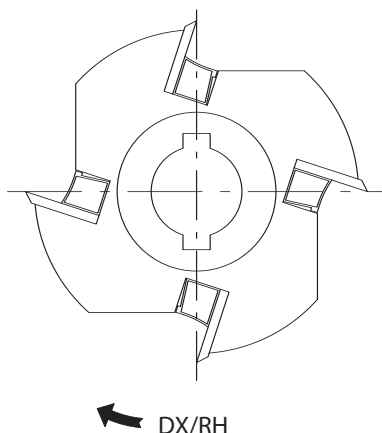

| Codice Code | R R | D D | D1 D1 | B B | b b | d d | DKN DKN | Rotazione Rotation | Cod. Prezzo Price Code | RICAMBI/Spare Parts | | |
|----------------|---------|--------|----------|--------|--------|--------|------------|-----------------------|---------------------------|---------------------|----------------|---------------|
| | | | | | | | | | | Coltello Knife | Cuneo Wedge | Vite Screw |
| 2276.010.001 | 1/1,5/2 | 75,4 | 60 | 25 | 21 | 20 | 6x2,8 | Dx/Rh | F24 | 8208.000.001 | 8281.140.000 | 8285.006.000 |
| 2276.010.002 | 1/1,5/2 | 75,4 | 60 | 25 | 21 | 20 | 6x2,8 | Sx/Lh | F24 | 8208.000.002 | 8281.140.000 | 8285.006.000 |
| 2276.020.001 | 1,5/2/3 | 75,4 | 60 | 25 | 21 | 20 | 6x2,8 | Dx/Rh | F24 | 8208.000.003 | 8281.140.000 | 8285.006.000 |
| 2276.020.002 | 1,5/2/3 | 75,4 | 60 | 25 | 21 | 20 | 6x2,8 | Sx/Lh | F24 | 8208.000.004 | 8281.140.000 | 8285.006.000 |

2277

FRESE HW PER BORDATRICI "BIESSE" TCT CUTTERS FOR BIESSE EDGEBANDING MACHINES

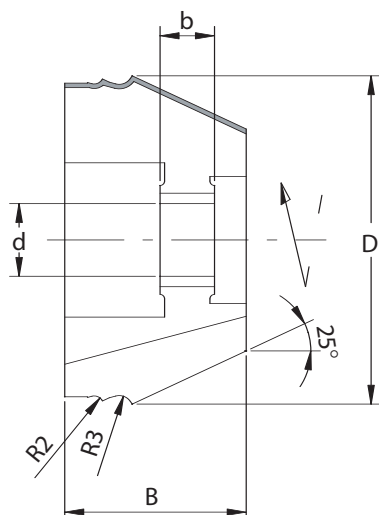
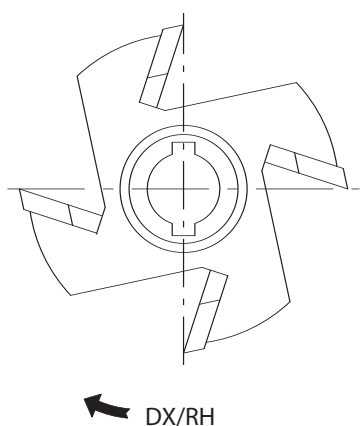

HW **Z=4** **MEC** Avanzamento meccanico
Mechanical feed

| Codice Code | R R | D D | B B | b b | d d | DKN DKN | Rotazione Rotation | Cod. Prezzo Price Code |
|----------------|-----------|--------|--------|--------|--------|------------|-----------------------|---------------------------|
| 2277.000.001 | R2 R3 25° | 72,35 | 40 | 10,5 | 16 | 5x2,3 | Dx/Rh | M25 |
| 2277.000.002 | R2 R3 25° | 72,35 | 40 | 10,5 | 16 | 5x2,3 | Sx/Lh | M25 |