



APPLICAZIONE/APPLICATION:

Realizzazione profili sagomati su disegno.
Production different types of customer made profiles.

MACCHINA/MACHINE:

Toupie, scorniciatrici, profilatrici.
Shapers, moulders, double end tenoners.

INFORMAZIONI TECNICHE/TECHNICAL INFORMATION:

Esecuzione con coltelli intercambiabili in HW integrale micrograno - si costruiscono con angoli idonei alla lavorazione dei diversi tipi di legno.

Manufactured with solid carbide micrograin knives. Produced with suitable cutting angles for different types of wood.

foro "d" da 30 a 50 mm

HW Avanzamento manuale
Manual feed

MAN Avanzamento manuale
Manual feed

MEC Avanzamento meccanico
Mechanical feed

Z=2 - Art. 2365

Codice Code	D D	S S	Cod. Prezzo Price Code
2365.140.030	140	30	F25
2365.140.040	140	40	B26
2365.140.050	140	50	H26
2365.140.060	140	60	C27
2365.160.030	160	30	B26
2365.160.040	160	40	H26
2365.160.050	160	50	C27
2365.160.060	160	60	H27
2365.180.030	180	30	E26
2365.180.040	180	40	C27
2365.180.050	180	50	L27
2365.180.060	180	60	D28
2365.200.030	200	30	G27
2365.200.040	200	40	A28
2365.200.050	200	50	F28
2365.200.060	200	60	B29

Z=3 - Art. 2370

Codice Code	D D	S S	Cod. Prezzo Price Code
2370.140.030	140	30	C28
2370.140.040	140	40	M28
2370.140.050	140	50	G29
2370.140.060	140	60	B30
2370.160.030	160	30	M28
2370.160.040	160	40	G29
2370.160.050	160	50	E30
2370.160.060	160	60	M30
2370.180.030	180	30	G29
2370.180.040	180	40	E30
2370.180.050	180	50	A31
2370.180.060	180	60	E31
2370.200.030	200	30	L30
2370.200.040	200	40	B31
2370.200.050	200	50	G31
2370.200.060	200	60	A32

Z=4 - Art. 2375

Codice Code	D D	S S	Cod. Prezzo Price Code
2375.140.030	140	30	C31
2375.140.040	140	40	L31
2375.140.050	140	50	F32
2375.140.060	140	60	M32
2375.160.030	160	30	L31
2375.160.040	160	40	F32
2375.160.050	160	50	A33
2375.160.060	160	60	F33
2375.180.030	180	30	F32
2375.180.040	180	40	A33
2375.180.050	180	50	H33
2375.180.060	180	60	A34
2375.200.030	200	30	F33
2375.200.040	200	40	L33
2375.200.050	200	50	D34
2375.200.060	200	60	G34

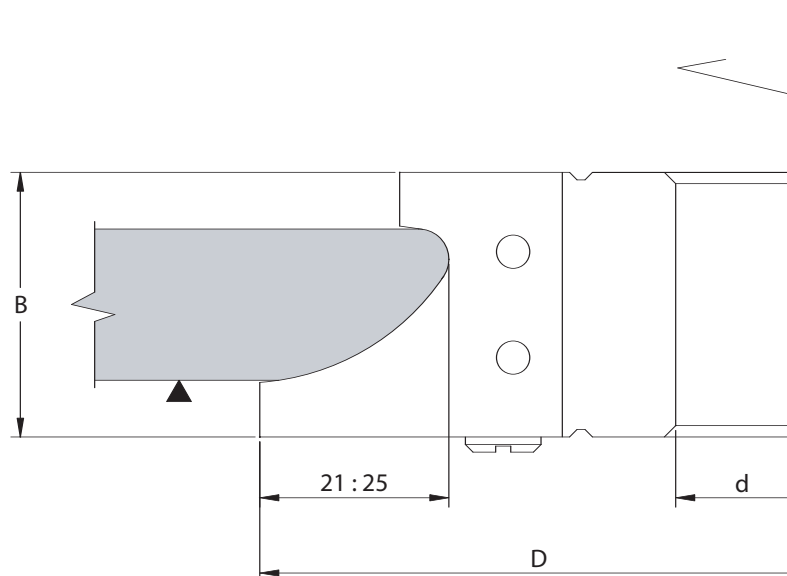

RICAMBI/Spare Parts	ARTICOLO/Article
Coltello/knife	8170
Vite/Screw	8285.008.000
Chiave/Key	8350.040.000
Cuneo/Wedge	8284