



BUP[®]
KESİCİ TAKIMLAR

2019



www.bup.com.tr



HAKKIMIZDA

BUP Utensili ahşap işleme endüstrisinde, dünya genelinde üretim ve satış gerçekleştirmektedir.

Firmamız 50 yıllık deneyimi ile ahşap işleme makineleri için her türlü; standart ve özel kesici takımları üretmektedir.

Günümüz kesici takım üretim süreci, teknolojik tasarım ve çizim ekipmanlarından yararlanmak durumundadır. Öncelikle, kesici takımlar bilgisayar ortamında CAD ve CAD/CAM grafik tabanlı yazılımlar kullanılarak tasarlanır. Yüksek kalitede üretimi gerçekleştirecek olan numerik kontrollü makinelerde çalışabilecek kesici takımların, 3D ve grafik yazılımlar ile tasarlanması gerekir.

BUP Utensili; geleneksel ve otomatik makineler ve de CNC işlem merkezleri için HM değişebilir uçlu ve Diamond uçlu takımları çabuk teslim süreleri içinde üretir.

BUP Utensili son yıllarda kesici takım pazarlarındaki payını oldukça yükseltmiş ve dünya genelinde bilinir bir marka haline gelmiştir.

Yüksek nitelikli pazarlama grubu ile üretiminin %60'ını Rusya, Amerika, Kanada, Meksika, Avustralya, İskandinav ülkeleri, Türkiye, İspanya, İngiltere, Ortadoğu, Çin ve Hindistan gibi ülkelere gerçekleştirmektedir.

BUP Utensili 2008 yılı Ocak ayından itibaren kendi faaliyet alanında 50 yıllık bilgi ve birikimi ile Türkiye'de **BUP Kesici Takımlar San. ve Tic. Ltd. Şti.** ünvanı ile faaliyete başlamıştır.



HW Daire Testereleler



BUP[®]
UTENSILI



www.buputensili.it

9010

HM: AHŞAP KESİM TESTERELERİ

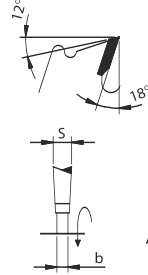
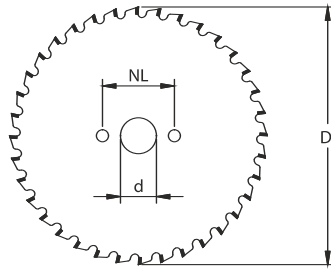

* Limitörlü ahşap kesim testeresi

KOD.	D	S	b	d	Z	A
9010 250 3230F24	250	3,2	2,2	30	24	A
9010 300 3230F28	300	3,2	2,2	30	28	A
9010 350 3530F32	350	3,5	2,5	30	32	A
9010 400 4030F36	400	4,0	2,8	30	36	A
9010 450 4030F40	450	4,2	2,8	30	40	A
9010 500 4030F44	500	4,2	2,8	30	44	A

9041

HM: SUNTALAM ve MDF-LAM KESİM TESTERELERİ

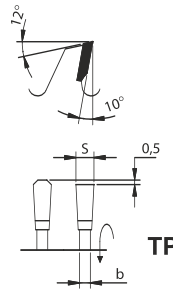
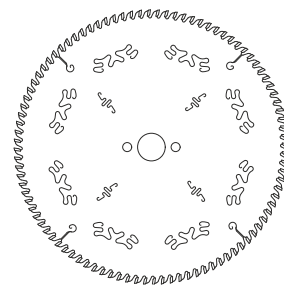

* Suntalam ve mdf-lam panel ebatlama testeresi
* Low-noise düşük sesli gövde

KOD.	D	S	b	d	Z	TP
9040 200 3230F64	200	3,2	2,2	30	64	TP
9040 220 3230F64	220	3,2	2,2	30	64	TP
9041 250 3230F80	250	3,2	2,2	30	80	TP
9041 300 3230F96	300	3,2	2,2	30	96	TP
9041 350 3530F108	350	3,5	2,5	30	108	TP
9041 400 4030F120	400	4,0	2,8	30	120	TP

9060

HM: KONİK ÇİZİCİ TESTERELER

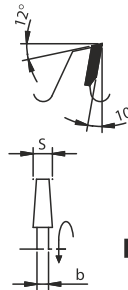
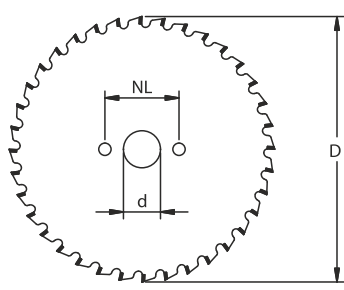

* Suntalam ve MDF-lam panel ebatlama konik çizici testeresi

KOD.	D	S	b	d	Z	KON
9060 100 312020	100	3,1	2,2	20	20	KON
9060 120 312020	120	3,1	2,2	20	20	KON
9060 120 312220	120	3,1	2,2	22	20	KON
9060 125 312024	125	3,1	2,2	20	24	KON
9060 125 312224	125	3,1	2,2	22	24	KON

9005

HM: UNIVERSAL TESTERELER

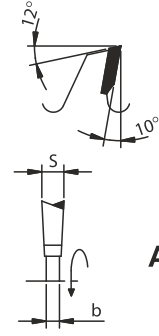
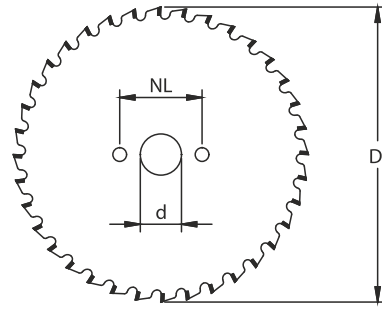

A

KOD. RH - LH	D	S	b	d	Z	
9005 150 3230F36	150	3,2	2,2	30	36	A
9005 180 3230F36	180	3,2	2,2	30	36	A
9005 180 3230F48	180	3,2	2,2	30	48	A
9005 200 3230F64	200	3,2	2,2	30	64	A
9005 250 3230F48	250	3,2	2,2	30	48	A
9005 250 3230F60	250	3,2	2,2	30	60	A
9005 250 3230F80	250	3,2	2,2	30	80	A
9005 300 3230F72	300	3,2	2,2	30	72	A
9005 300 3230F96	300	3,2	2,2	30	96	A
9005 350 3530F60	350	3,5	2,5	30	60	A
9005 350 3530F72	350	3,5	2,5	30	72	A
9005 350 3530F84	350	3,5	2,5	30	84	A
9005 350 3530F108	350	3,5	2,5	30	108	A
9005 400 4030F80	400	4,0	2,8	30	80	A
9005 400 4030F96	400	4,0	2,8	30	96	A
9005 400 4030F120	400	4,0	2,8	30	120	A
9005 450 4230F72	450	4,2	2,8	30	72	A
9005 500 4230F120	500	4,2	2,8	30	120	A

9046

HM: AYARLANABİLİR ÇİZİCİ TESTERELER

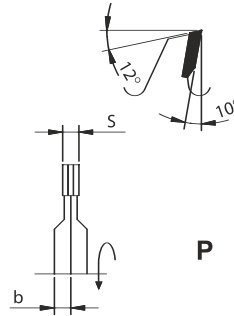
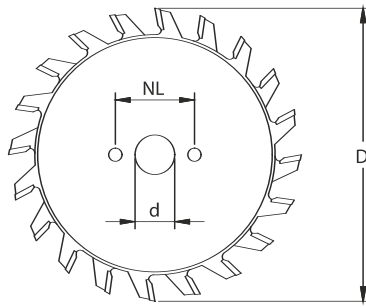

P

* İki parçalı, pul ile ayarlanabilir çizici testereler

KOD. RH - LH	D	S	b	d	Z	
9046 100 2820F10	100	2,8:3,6	2,2	20	10+10	
9046 100 2822F10	100	2,8:3,6	2,2	22	10+10	
9046 120 2820F12	120	2,8:3,6	2,2	20	12+12	
9046 120 2822F12	120	2,8:3,6	2,2	22	12+12	ALTENDORF
9046 125 2820F12	125	2,8:3,6	2,2	20	12+12	
9046 125 2822F12	125	2,8:3,6	2,2	22	12+12	
9046 200 4320F30	200	4,3:5,2	2,2	20	30+30	SCM

9080

HM: ÇOKLU DİLİMLEME TESTERELERİ

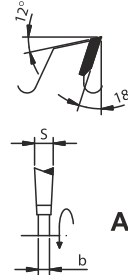
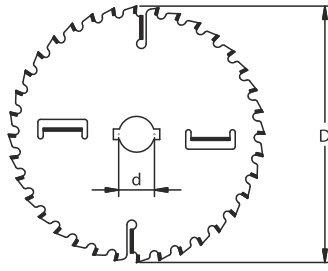

* Masif ağaç boyuna dilimleme testereleri

KOD.	D	S	b	d	DKW	Z
9080 250 2770K204	250	2,7	1,8	70		20+2+2
9080 250 3270K204	250	3,2	2,2	70		20+2+2
9080 300 3270K244	300	3,2	2,2	70		24+2+2
9080 300 2775K244	300	2,7	1,8	75		24+2+2
9080 300 3275K244	300	3,2	2,2	75		24+2+2
9080 300 2780K244	300	2,7	1,8	80	RAIMANN	24+2+2
9080 300 3280K244	300	3,2	2,2	80	RAIMANN	24+2+2
9080 350 3570K246	350	3,5	2,5	70		24+2+4
9080 350 3880K246	350	3,8	2,8	80	RAIMANN	24+2+4
9080 350 3575K246	350	3,5	2,5	75		24+2+4
9080 350 3580K246	350	3,5	2,5	80	RAIMANN	24+2+4
9080 400 4075K286	400	4,0	2,8	75		28+2+4

9150

HM: ALÜMİNYUM KESİM TESTERELERİ

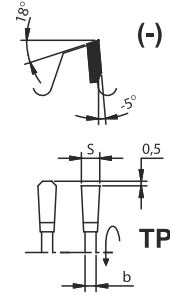
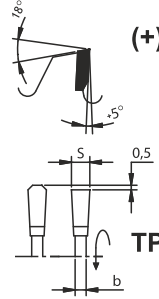
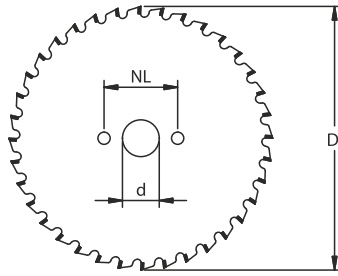

KOD.	D	S	b	d	Z	AÇI °
9150 250 3430F80	250	3,4	2,6	30	80	Negatif (-5°)
9150 250 3432F80	250	3,4	2,6	32	80	Negatif (-5°)
9150 300 3430F96	300	3,4	2,6	30	96	Negatif (-5°)
9150 300 3432F96	300	3,4	2,6	32	96	Negatif (-5°)
9150 350 3430F108	350	3,4	2,6	30	108	Negatif (-5°)
9150 350 3432F108	350	3,4	2,6	32	108	Negatif (-5°)
9150 400 4030F120	400	4,0	3,2	30	120	Negatif (-5°)
9150 400 4032F120	400	4,0	3,2	32	120	Negatif (-5°)
9150 420 4030F120	420	4,0	3,2	30	120	Negatif (-5°)
9150 420 4032F120	420	4,0	3,2	32	120	Negatif (-5°)
9150 450 4030F128	450	4,0	3,2	30	128	Negatif (-5°)
9150 450 4032F128	450	4,0	3,2	32	128	Negatif (-5°)
9150 500 4630F140	500	4,6	3,6	30	140	Negatif (-5°)
9150 500 4632F140	500	4,6	3,6	32	140	Negatif (-5°)

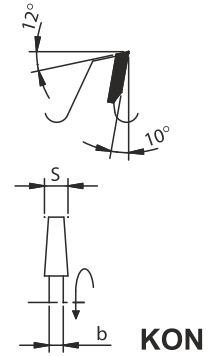
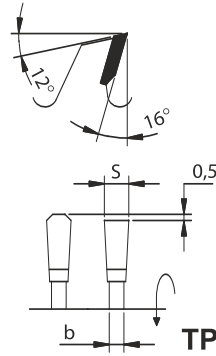
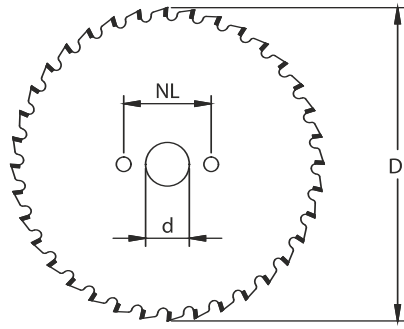
**GIBEN - SCM - GABBIANI**

KOD.	D	S	b	d	Z		
9035 300 4475F60	300	4,4	3,2	75	60	TP	Kesici
9035 350 4475F72	350	4,4	3,2	80	72	TP	Kesici
9035 380 4480F72	380	4,4	3,2	80	72	TP	Kesici
9035 400 4475F72	400	4,4	3,2	75	72	TP	Kesici
9035 430 4475F72	430	4,4	3,2	75	72	TP	Çizici
9060 125 4345F24	125	4,3	5,5	45	24	KON	Çizici
9060 160 4345F36	160	4,3	5,5	45	36	KON	Çizici
9060 160 4355F36	160	4,3	5,5	55	36	KON	Çizici
9060 180 4355F36	180	4,3	5,5	55	36	KON	Çizici
9060 200 4380F36	200	4,3	5,5	80	36	KON	Çizici
9060 200 4330F36	200	4,3	5,5	30	36	KON	Çizici

SELCO

9035 300 4665F60	300	4,6	3,2	65	60	TP	Kesici
9035 320 4665F60	320	4,6	3,2	65	60	TP	Kesici
9035 355 4465F72	355	4,4	3,2	65	72	TP	Kesici
9035 360 4665F72	360	4,6	3,2	65	72	TP	Kesici
9035 400 4680F72	400	4,6	3,2	80	72	TP	Kesici
9035 430 4665F72	430	4,6	3,2	65	72	TP	Kesici
9035 430 4680F72	430	4,6	3,2	80	72	TP	Kesici
9035 450 4880F72	450	4,8	3,5	80	72	TP	Kesici
9035 470 4880F72	470	4,8	3,5	70	72	TP	Kesici
9060 200 4365F36	200	4,3	5,5	65	36	KON	Çizici
9060 200 4565F36	200	4,5	5,7	65	36	KON	Çizici
9060 200 4765F36	200	4,7	6,0	65	36	KON	Çizici
9061 300 4865F72	300	4,8	3,2	65	72	TP	PF Çizici

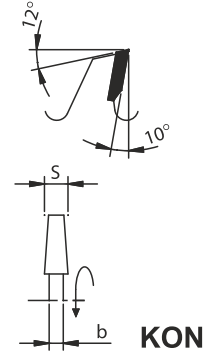
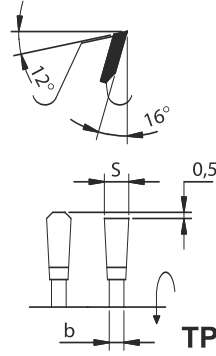
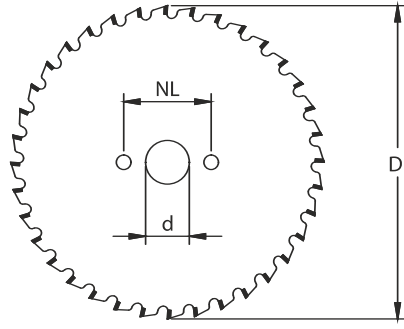
**HOLZMA**

KOD.	D	S	b	d	Z		
9035 380 4860F72	380	4,8	3,5	60	72	TP	Kesici
9035 450 4860F72	450	4,8	3,5	60	72	TP	Kesici
9060 180 4745F36	180	4,7	6,0	45	36	KON	Çizici
9060 200 4745F36	200	4,7	6,0	45	36	KON	Çizici

SCHELLING

9035 460 4430F72	460	4,4	3,2	30	72	TP	Kesici
9060 200 4320F36	200	4,3	5,5	20	36	KON	Çizici

HOLZ HER

9035 350 4430F72	350	4,4	3,2	30	72	TP	Kesici
9035 400 4430F72	400	4,4	3,2	30	72	TP	Kesici
9060 180 4330F36	180	4,3	5,5	30	36	KON	Çizici

MACMAZZA

9035 300 4475F60	300	4,4	3,2	75	60	TP	Kesici
9035 320 4475F72	320	4,4	3,2	75	72	TP	Kesici
9035 350 4475F72	350	4,4	3,2	75	72	TP	Kesici
9035 380 4475F72	380	4,4	3,2	75	72	TP	Kesici
9035 390 4475F72	390	4,4	3,2	75	72	TP	Kesici
9035 400 4475F72	400	4,4	3,2	75	72	TP	Kesici
9035 450 4475F72	450	4,4	3,2	75	72	TP	Kesici
9060 160 4355F36	160	4,3	3,2	55	36	KON	Çizici
9060 280 4655F48	280	4,6	3,2	55	48	TP	PF Çizici

9055 - 9056

HM: BAŞ - SON KESİM TESTERELERİ

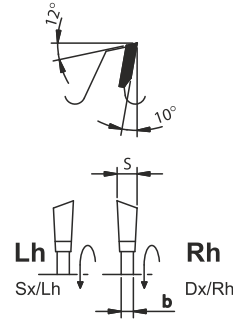
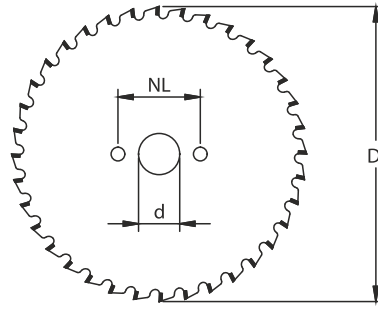

KOD.	D	S	b	d	Z		
9055 - 9056 100 2632	100	2,6	1,8	32	30	Brandt	Sağ-Sol
9055 110 3622	110	3,6	2,8	22	20	Holz-Her	
9055 - 9056 115 2630	115	2,6	1,8	30	24	Stefani	Sağ-Sol
9055 - 9056 150 3235	150	3,2	2,2	35+4	48	Stefani	Sağ-Sol
9055 160 3222	160	3,2	2,2	22	36	Ima	
9055 - 9056 130 3630	130	3,6	2,8	30+4	20+4	Biesse	Sağ-Sol
9055 140 3630	140	3,6	2,8	30+ (3+3)	36	Biesse	
9055 - 9056 140 3630	140	3,6	2,8	30+4	16+4	Biesse	Sağ-Sol
9055 - 9056 120 3640	120	3,6	2,8	40+8	36	Homag	Sağ-Sol

9140

HM: KANAL AÇMA TESTERELERİ

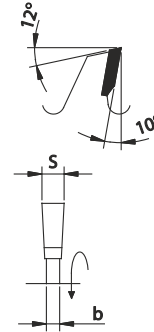
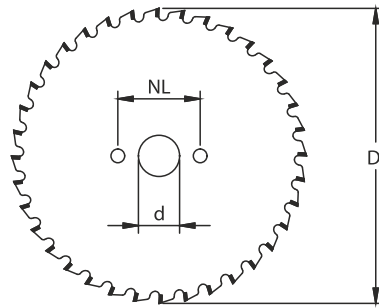

KOD.	D	S	d	Z	
9140 125 403012	125	4,0	30	12	
9140 125 503012	125	5,0	30	12	
9140 125 903012	125	9,0	30	12	
9140 150 403012	150	4,0	30	12	
9140 150 503012	150	5,0	30	12	
9140 150 903012	150	9,0	30	12	
9140 125 505512	125	5,0	55+6	12	Biesse Akron
9140 125 905512	125	9,0	55+6	12	Biesse Akron
9140 150 406512	150	4,0	65+6	12	Homag - Ima
9140 150 506512	150	5,0	65+6	12	Homag - Ima
9140 150 906512	150	9,0	65+6	12	Homag - Ima
9140 180 503018	180	5,0	30	18	
9140 180 903018	180	9,0	30	18	

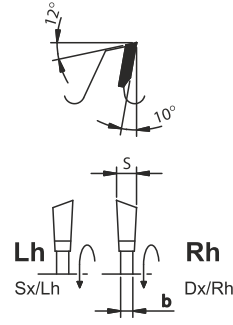
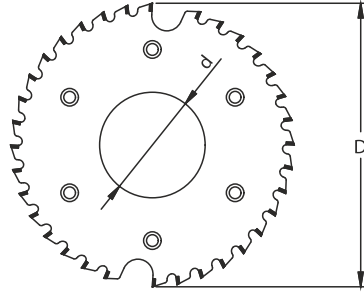
9125 - 9126**HM: ÇİFT TARAFLI PARÇALAYICI TESTERELERİ**

KOD. RH - LH	D	S	b	d	NL	Z
9125 - 9126 205 4180F48	205	4,1	2,8	80+3	Leuco	48
9125 - 9126 205 4180F57	205	4,1	2,8	80+3	Leuco	57
9125 - 9126 255 4110F54	255	4,1	2,8	100+6	Leuco	54
9125 - 9126 255 4113F58	255	4,1	2,8	130+6	Bup	58
9125 - 9126 255 4113F60	255	4,1	2,8	130+4	Witox	60
9125 - 9126 255 4110F72	255	4,1	2,8	100+6	Leuco	72
9125 - 9126 355 4180F80	355	4,1	2,8	80+6	Leitz	80

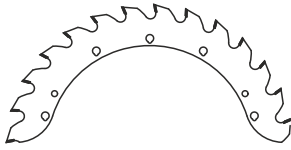
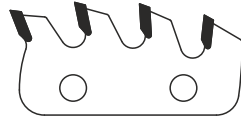
9130 - 9131**HM: ÇİFT TARAFLI PARÇALAYICI SEGMENTLERİ****A****B****C****D**

KOD. RH - LH	D	S	b		NL	Z
9130 - 9131 250 4027F14	250	4,0	2,7	A	Bup	14
9130 - 9131 225 4027F04	225	4,0	2,7	B	Leuco	4
9130 - 9131 250 5228F07	250	5,2	2,8	C	Witox	7
9130 - 9131 350 4527F10	350	4,5	2,7	D	Leitz	10

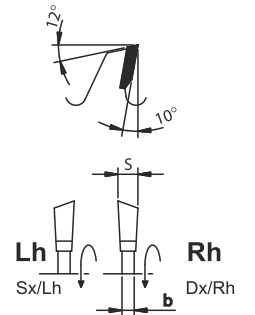
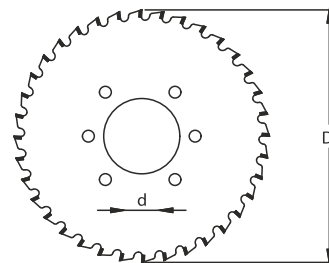
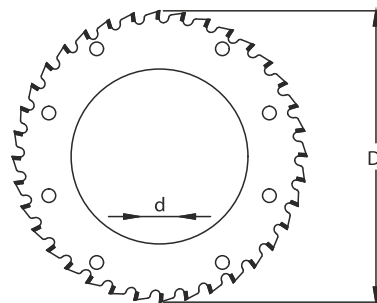
9145**HM: FINGER JOINT TESTERELERİ**

KOD.	D	S	b	d	Z		
9145 250 8180 F60	250	8,0	6,1	80+8	60	Sağ	Weinig Grecon
9146 250 8180 F60	250	8,0	6,1	80+8	60	Sol	Weinig Grecon
9145 200 5175 F48	200	5,1	3,5	75+6	48	Sağ	Weinig Grecon
9146 200 5175 F48	200	5,1	3,5	75+6	48	Sol	Weinig Grecon

CNC Makina Freze Biçakları



BUP[®]
UTENSILI



www.buputensili.it

5 4

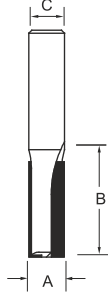
4156**HM: DÜZ UÇLU FREZELER**

- * Çelik gövdeli
- * Düz ağızlı
- * Z.2

KOD. RH	d	S	D	Z
	3	8	8	2
	4	10	8	2
	5	16	8	2
	6	19	8	2
	8	20	8	2
	8	32	12	2
	10	20	12	2
	10	32	12	2
	12	20	12	2
	12	38	12	2

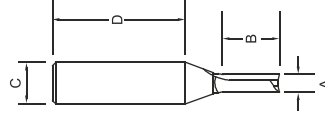
4152**HM: SOM KARBÜR UÇLU PARMAK FREZE**

- * Solid sert metal uçlu
- * Çelik gövdeli
- * Düz ağızlı
- * Z.2

KOD. RH	d	S	D	Z
	4	20	8	2
	6	26	8	2
	8	32	12	2

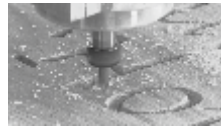
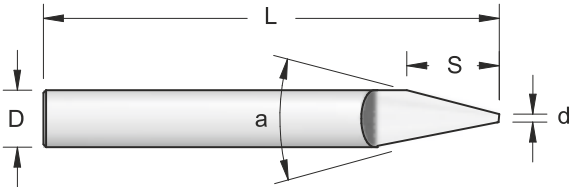
4031**HM: V UÇLU YAZI ve OYMA FREZELERİ**

- * Solid sert metal uçlu
- * Düz ağızlı
- * Z.1
- * 30°

KOD. RH	d	S	L	D	Z	a
4031 010 014	0,1	14	50	6	1	30°
4031 025 014	0,25	14	50	6	1	30°
4031 050 014	0,50	14	50	6	1	30°
4031 100 014	1	14	50	6	1	30°

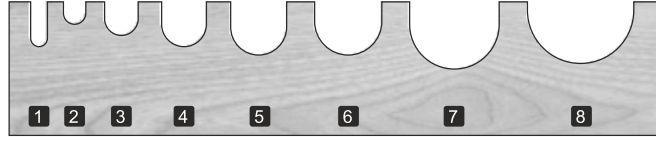
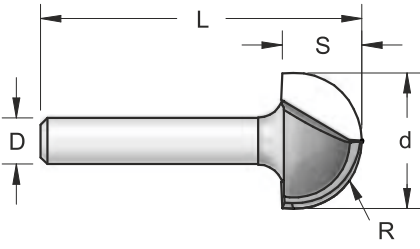
4040**HM: KÜRE UÇLU FREZELER**

- * Sert metal uçlu
- * Çelik gövdeli
- * Küre ağızlı
- * Z.2

KOD. RH	d	S	D	Z	R
4040 030 080	3	8	8	2	1,5
4040 040 040	4	4	8	2	2
4040 060 060	6	6	8	2	3
4040 080 080	8	8	12	2	4
4040 100 095	10	9,5	8	2	5
4040 120 095	12	9,5	12	2	6
4040 160 120	16	12	12	2	8
4040 190 110	19	11	12	2	9,5
4040 254 190	25,4	19	12	2	12,7
4040 381 222	38,1	22,22	12	2	19,5

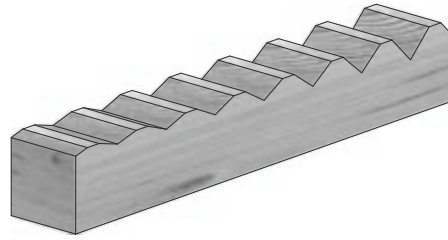
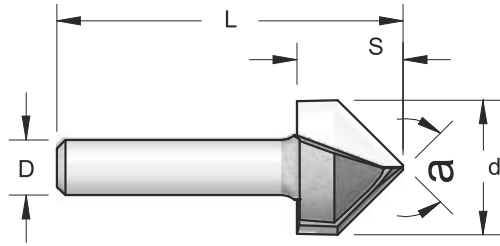
4031**HM: V UÇLU FREZELER**

- * Sert metal uçlu
- * Çelik gövdeli
- * V ağızlı
- * Z.2

KOD. RH	d	S	D	Z	AÇI
4031 207 240	20,78	24	12	2	60°
4031 127 159	12,7	15,9	8	2	60°
4031 680 402	68	40,25	12	2	90°
4031 400 254	40	25,4	12	2	90°
4031 190 160	19	16	12	2	90°
4031 127 127	12,7	12,7	8	2	90°
4031 600 254	60	25,4	12	2	120°
4031 400 145	40	14,55	12	2	120°
4031 400 127	40	12,7	12	2	140°
4031 600 127	60	12,7	12	2	140°
4031 601 127	60	12,7	12	2	150°
4031 401 127	40	12,7	12	2	150°

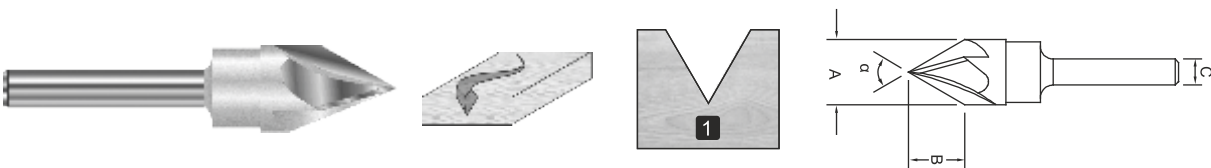

* Yazı frezesi

4031 000 002	15,1	13,1	12	2	60°
--------------	------	------	----	---	-----

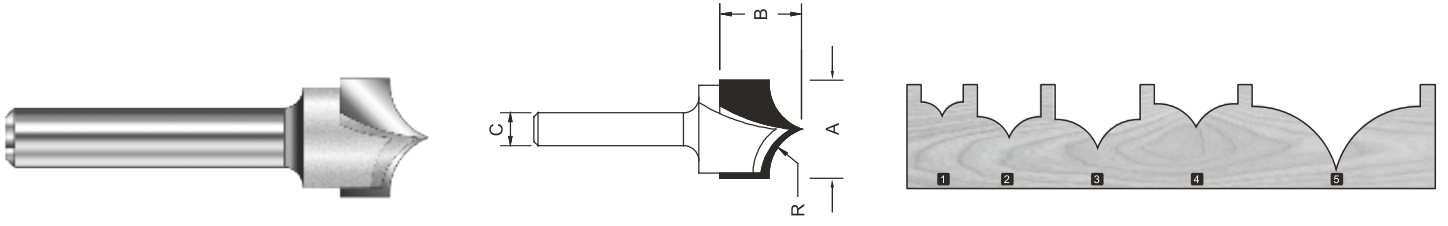
4032**HM: RADÜSLÜ PROFİL FREZE**

KOD. RH	d	S	D	Z	R
4032 127 095	12,7	9,5	12	2	6,35
4032 191 158	19,1	15,8	12	2	9,5
4032 254 191	25,4	19,1	12	2	12,7
4032 250 127	25	12,7	12	2	12,5
4032 500 255	50	25,5	12	2	25

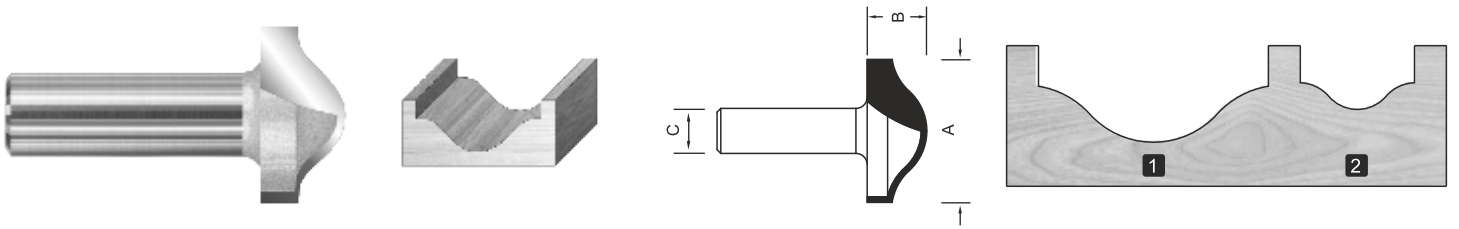
4011**HM: PROFİL FREZE**

KOD. RH	d	S	D	Z
4011 381 159	38,1	15,9	12	2
4011 191 105	19,1	10,5	12	2

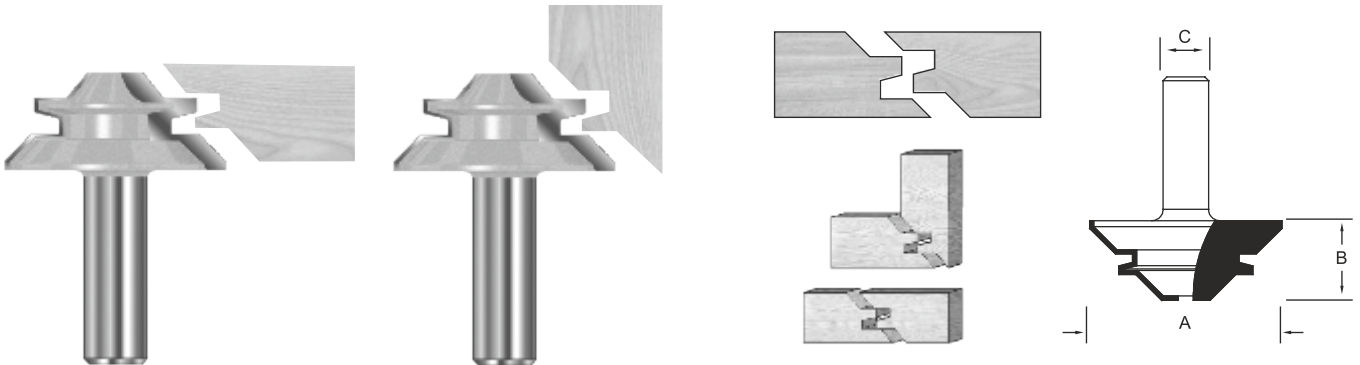
4012**HM: KÖŞE BİRLEŞTİRME FREZESİ**

KOD. RH	d	S	D	Z
4012 381 127	38,1	12,7	8	2
4012 444 210	44,45	21	12	2

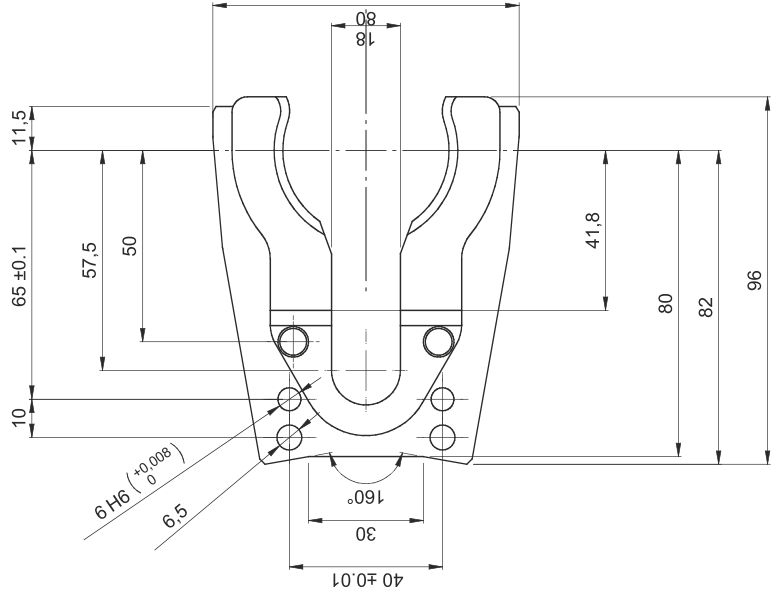
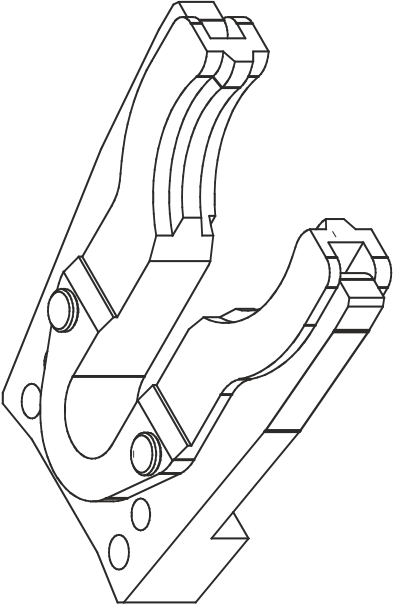
430I**CNC TAKIM TUTUCU ISO 30****KOD. RH****AÇIKLAMA**

4301 000 001

ISO 30

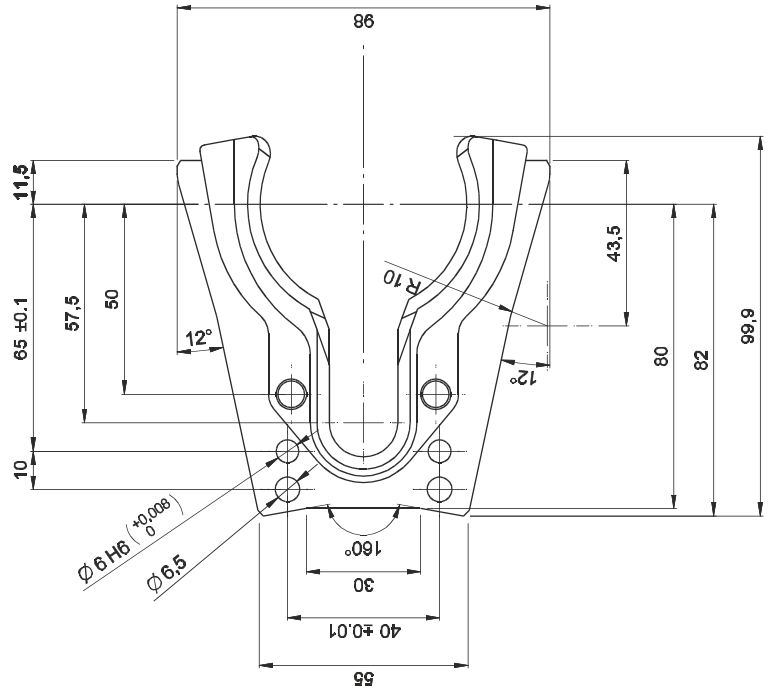
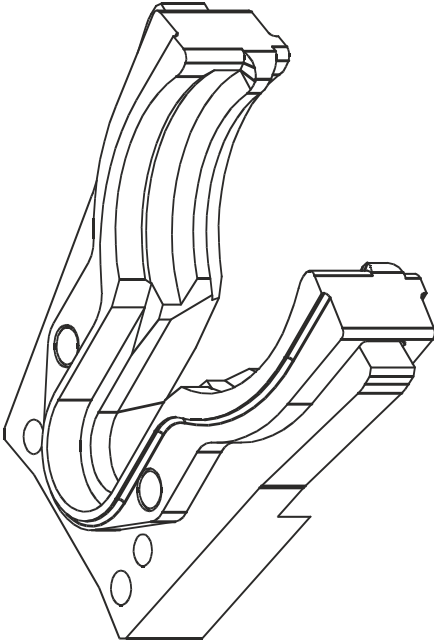
430I**CNC TAKIM TUTUCU HSK 63 F****KOD. RH****AÇIKLAMA**

4301 000 002

HSK 63 F

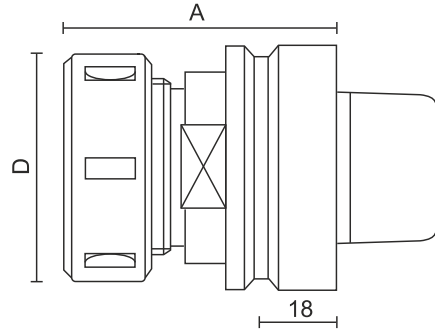
4112**HSK 63 F CNC ADAPTÖR**

* Biesse, Ima, Weke, Holz-Her

KOD.	D	A	Pens	Dönüş Yönü	
4112 010 001	50	76	ø 3-20	ER 32	Sağ
4112 010 002	50	76	ø 3-20	ER 32	Sol
4112 020 001	63	76	ø 3-25	ER 40	Sağ
4112 020 002	63	76	ø 3-25	ER 40	Sol

4113-4114**ISO 30 CNC ADAPTÖR**

* SCM, Morbidelli

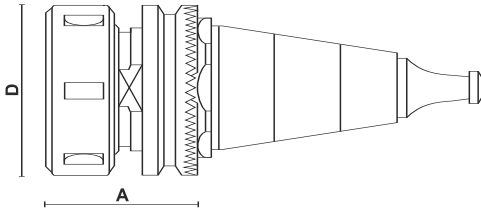

* Biesse, Masterwood

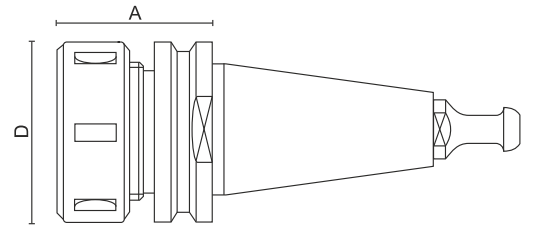

KOD.	D	A	Pens	Dönüş Yönü		
4113 010 001	50	55	ø 3-20	ER 32	Sağ	SCM, Morbidelli
4113 010 002	50	55	ø 3-20	ER 32	Sol	SCM, Morbidelli
4114 010 001	50	50	ø 3-20	ER 32	Sağ	
4114 010 002	50	50	ø 3-20	ER 32	Sol	
4114 020 001	63	50	ø 3-25	ER 40	Sağ	
4114 020 002	63	50	ø 3-25	ER 40	Sol	

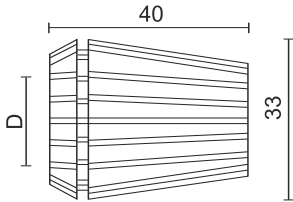
4116 - 4117**PENS**

ER 32

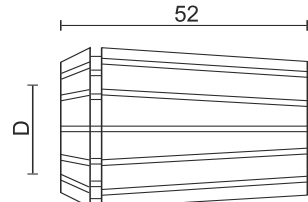

DIN 6388

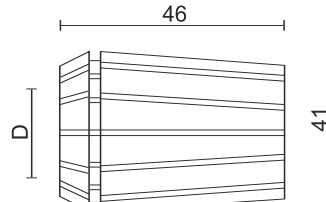

ER 40

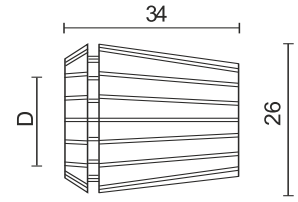

ER 25

KOD.	D	S	d	
4116 (030...200) 000	33	40	3-20	ER 32
4116 (030...250) 001	35	52	3-25	DIN 6388
4116 (030...250) 002	41	46	3-25	ER 40
4117 (030...160) 000	26	34	3-16	ER 25

4300 - 8355**CNC ADAPTÖR AÇMA - KAPAMA APARATI**

* ISO30-HSK63

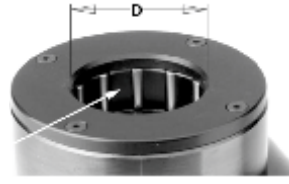

* ER32 - ER40 YARIM AY ANAHTAR

KOD. RH	TYPE	D	AÇIKLAMA
4300 000 001	ISO30	50	AÇMA - KAPAMA APARATI
4300 000 005	HSK 63 F	63	AÇMA - KAPAMA APARATI
8355 055 000	ER32	-	YARIM AY ANAHTAR
8355 065 000	ER40	-	YARIM AY ANAHTAR

4112**CNC HYDRO ADAPTÖR**Sıkıştırma Vidası
ve Pistonu
6-10 NmTakım tutucu şaft
HSK 63
ISO 30

- * Yüksek hassasiyetli hidrolik CNC adaptörler.
- * Kolay montaj ve takım değişirme.
- * Yüksek sıkıştırma gücü.
- * Hızlı ve temiz kesim.

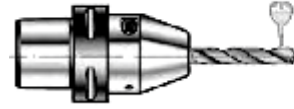
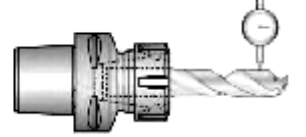
Hydraulic type
Salgı ≤ 0.004 mmCollet types
Salgı 0.02 – 0.04 mm

KOD. RH	TYPE	d
4112 050 020	ISO30	3-25
4112 051 020	HSK 63 F	3-25

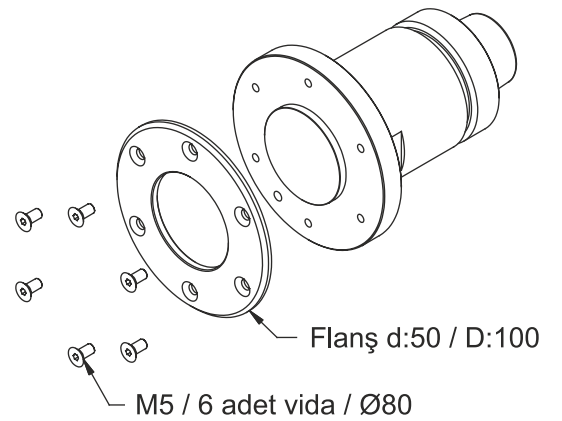
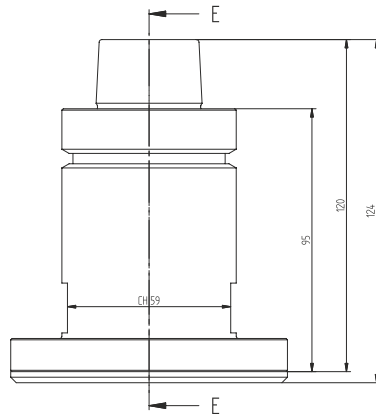
4112**CNC 5 EKSEN TESTERE ADAPTÖRÜ**

Flanş d:50 / D:100

M5 / 6 adet vida / Ø80

KOD. RH	TYPE	d	D	L	H
4112 124 100	HSK 63 F	50+7	100	124	95

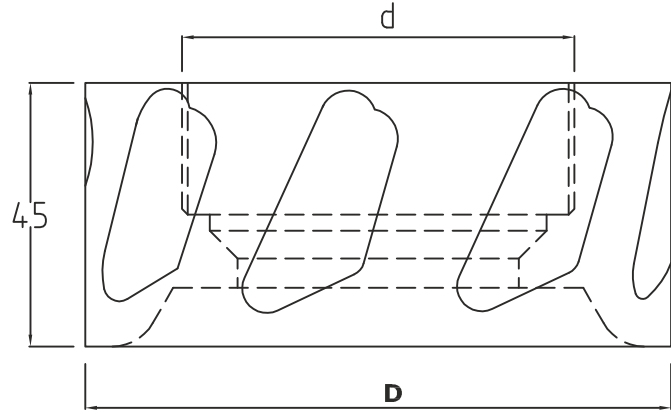

- * Standart HSK veya ISO30 adaptörle kullanılması mümkün ve kolay montaj
- * Hafif alaşım metalden üretilir
- * ER32, Er40 ve Din6388 (EOC25) pens ile kullanılır
- * Nesting operasyonları ebatlama ve profil işlemede kullanılır.
- * Max. RPM 20000, G2,5 balans değeri

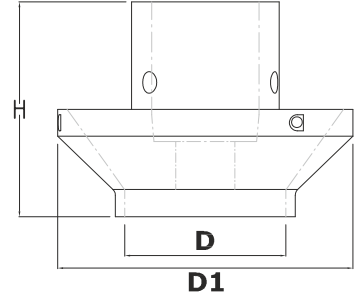
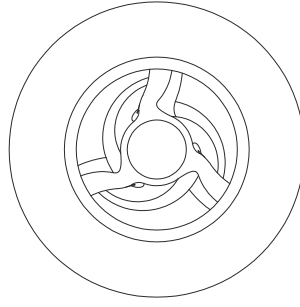

KOD. RH	AÇIKLAMA
4310 080 032	VORTEX D. 80 ER 32 RH - M40x1,5
4310 080 040	VORTEX D. 80 ER 40 RH - M50x1,5
4310 080 000	VORTEX D. 80 Din 6388 RH - M48x2
4310 100 032	VORTEX D. 100 ER 32 RH - M40x1,5
4310 100 040	VORTEX D. 100 ER 40 RH - M50x1,5
4310 100 000	VORTEX D. 100 Din 6388 RH - M48x2

4315**"HYDRO VORTEX" TALAŞ BOŞALTMA SİSTEMİ**

- * Vortex talaş boşaltma sistemi hafif alaşım metallardan üretilmiştir.
- * Hidrolik adaptörlere monte edilir.
- * Özel tasarımı sayesinde toz ve talaşı toz emici borulara yönlendirir.
- * Makina ve iş parçasının temiz kalmasını sağlar.
- * Gövde yapısı sayesinde sessiz çalışır.
- * Nesting operasyonları ebatlama ve profil işlemede kullanılır.
- * Max. RPM 20000, G2,5 balans değeri

KOD.**Açıklama****D x D1 x H**

4315 110 000

HYDRO VORTEX D. 110

110 x 60 x 80

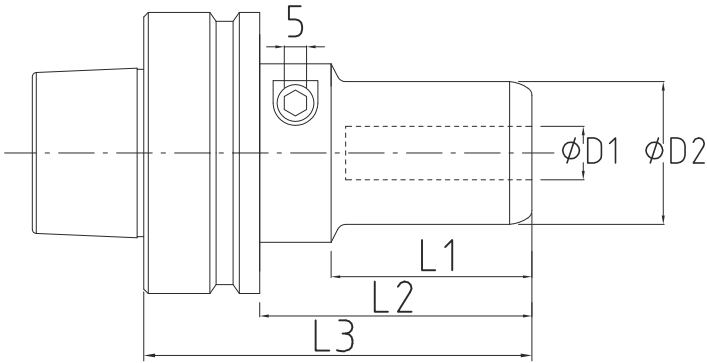
4108**CNC HYDRO ADAPTÖR HSK 63 F**

- * Hydro takım tutucular ince ve kompakt yapıda özel çelik hammaddeden üretilir
- * 12 - 16 - 20 - 25 mm çaplarda mevcuttur, mükemmel merkezleme
- * Max. RPM 25000, G2,5 balans değeri
- * Basit açma-kapama basınç vidasıyla kolay kullanım
- * Yüksek performans gerektiren operasyonlarda yüksek devir ve yüksek hız
- * Hydro Vortex ile birlikte kullanımında yüksek kesim kalitesi ve uzun takım ömrü

KOD.**Açıklama****D1 x D2****L1 - L2 - L3**

4108 012 000

HYDRO ADAPTÖR HSK 63F

D.12 - D.32

43 - 61 - 87

4108 016 000

HYDRO ADAPTÖR HSK 63F

D.16 - D.32

43 - 61 - 87

4108 020 000

HYDRO ADAPTÖR HSK 63F

D.20 - D. 40

55 - 73 -99

4108 025 000

HYDRO ADAPTÖR HSK 63F

D.25 - D.45

59 - 77 -103

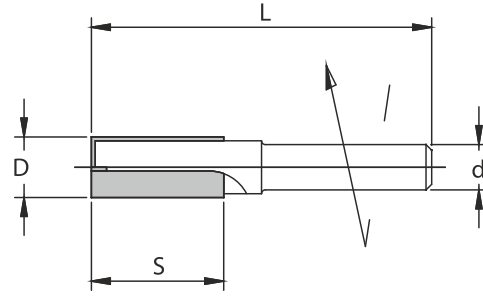
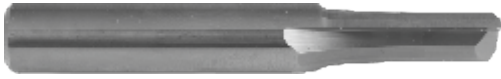
4155**HM: SOLID DÜZ UÇLU FREZELER Z.2**

- * Solid Sert Metal
- * Düz Ağızlı
- * Z.2

KOD. RH	D	S	L	d	Z
4155 030 011	3	11	60	6	2
4155 040 011	4	11	60	6	2
4145 040 023	4	23	75	6	2
4145 050 023	5	23	75	6	2
4155 050 011	5	11	60	6	2
4155 060 025	6	25	60	6	2
4160 070 025	7	25	60	10	2
4145 080 030	8	30	60	8	2
4145 090 022	9	22	52	10	2
4145 100 023	10	23	70	10	2
4145 100 040	10	40	87	10	2
4145 120 023	12	23	70	10	2
4145 120 040	12	40	87	10	2
4145 140 023	14	23	70	10	2
4145 140 040	14	40	87	10	2

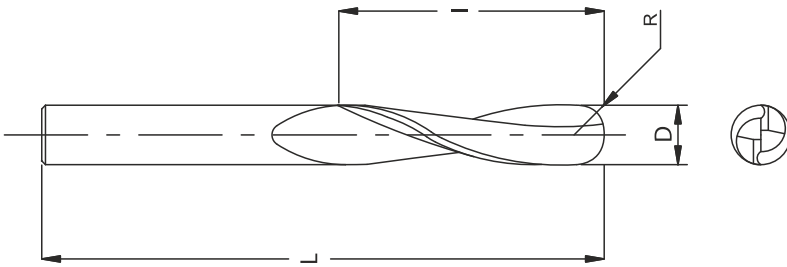
4177**HM: SOLID SPIRAL KÜRE UÇLU FREZELER Z.2**

- * 5 Eksenli Makinelerde MDF ve Ahşap Ebatlama, Profilleme ve Oyma Frezeleri
- * Solid Sert Metal
- * Spiral Up-Cut
- * Hassas Kesim
- * Z.2

KOD. RH	D	S	L	d	R	Z
4177 030 000	3	12	50	3	1,5	2
4177 040 000	4	12	50	4	2,0	2
4177 050 000	5	17	50	5	2,5	2
4177 060 000	6	27	60	6	3,0	2
4177 080 000	8	32	80	8	4,0	2
4177 100 000	10	42	100	10	5,0	2
4177 120 000	12	42	100	12	6,0	2
4177 140 000	14	52	100	14	7,0	2
4177 160 000	16	52	100	16	8,0	2
4177 180 000	18	72	120	18	9,0	2
4177 200 000	20	72	120	20	10,0	2

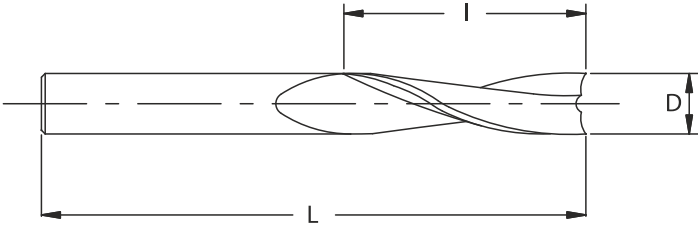
4175**HM: SOLID SPIRAL FREZELER Z.2 (TEMİZ KESİM)**

- * Sunta, MDF, Ahşap Ebatlama ve Kanal Açma Frezeleri
- * Solid Sert Metal
- * Spiral Ağızlı, up cut
- * Z.2

KOD. RH	D	S	L	d	Z
4175 030 012	3	12	50	3	2
4175 040 012	4	15	50	4	2
4175 050 017	5	17	50	5	2
4175 060 027	6	27	70	6	2
4175 080 032	8	32	80	8	2
4175 100 042	10	42	100	10	2
4175 120 042	12	42	100	12	2

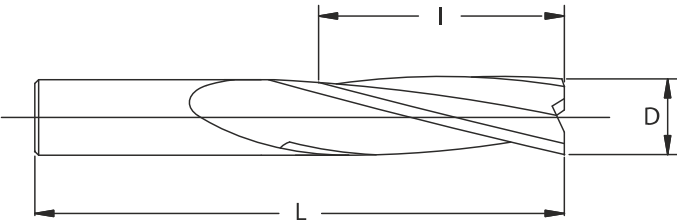
4185**HM: SOLID SPIRAL FREZELER Z.3 (TEMİZ KESİM)**

- * Sunta, MDF, Ahşap Ebatlama ve Kanal Açma Frezeleri
- * Solid Sert Metal
- * Spiral Ağızlı, up cut
- * Z.3

KOD. RH	D	S	L	d	Z
4185 100 032	10	32	80	10	3
4185 100 042	10	42	90	10	3
4185 120 042	12	42	100	12	3
4185 140 052	14	52	100	14	3
4185 160 052	16	52	100	16	3
4185 180 072	18	72	120	18	3
4185 200 072	20	72	120	20	3

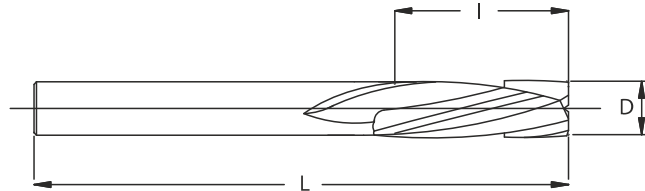
4212**HM: SOLID SPIRAL FREZELER (TEMİZ KESİM)**

- * Suntalam, MDF Lam, Ebatlama Frezeleri
- * Solid Sert Metal
- * Spiral Ağızlı
- * (+) Pozitif
- * (-) Negatif Açılı

KOD. RH	D	I	L	d	Z
4210 100 032	10	32	80	10	2+2
4210 120 042	12	42	100	12	2+2
4212 095 023	9,53	23	75	10	3+3
4212 100 032	10	32	80	10	3+3
4212 120 025	12	25	80	12	3+3

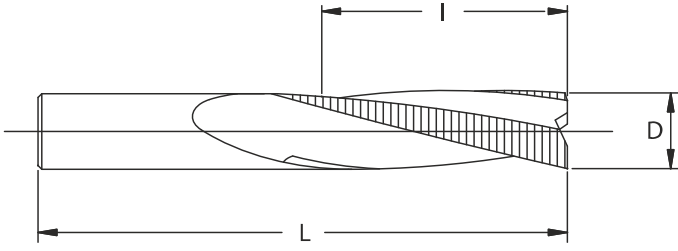
4195**HM: CNC SOLID SİRAL FREZELER Z.3 (KABA KESİM)**

- * Sunta, MDF ve Ahşap Ebatlama Frezeleri
- * Solid Sert Metal
- * Helisel Up-Cut
- * Kaba Kesim
- * Z.3

KOD. RH	D	S	L	d	Z
4195 080 032	8	32	72	8	3
4195 100 042	10	42	100	10	3
4195 120 042	12	42	100	12	3
4195 120 052	12	52	100	12	3
4195 140 042	14	42	100	14	3
4195 140 052	14	52	100	16	3
4195 160 052	16	52	100	16	3
4195 160 062	16	62	106	16	3

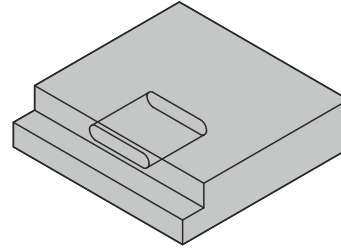
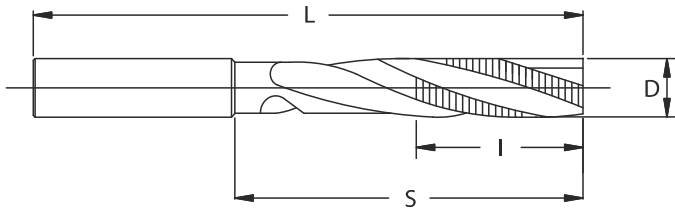
4205**HM: CNC KAPI KİLİT YUVASI FREZELERİ**

- * Kaba Kesim
- * Yatay Çalışma
- * Z.3

KOD. RH	D	I	S	L	Z
4205 140 100	14	45	95	150	3
4205 160 100	16	45	95	150	3
4205 180 100	18	45	95	150	3
4205 200 100	20	45	95	150	3

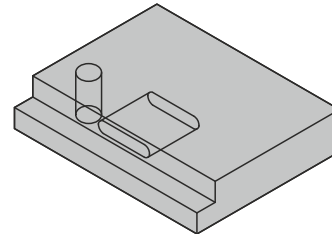
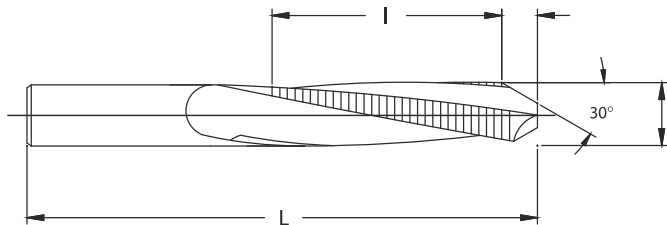
4207**HM: CNC KAPI KOL VE KİLİT DELİĞİ FREZELERİ**

- * Kaba Kesim
- * Dikey Çalışma
- * Z.3

KOD. RH	D	I	L	Z
4207 120 000	12	45	100	3
4207 140 000	14	44	100	3
4207 160 000	16	53	106	3
4207 180 000	18	65	125	3

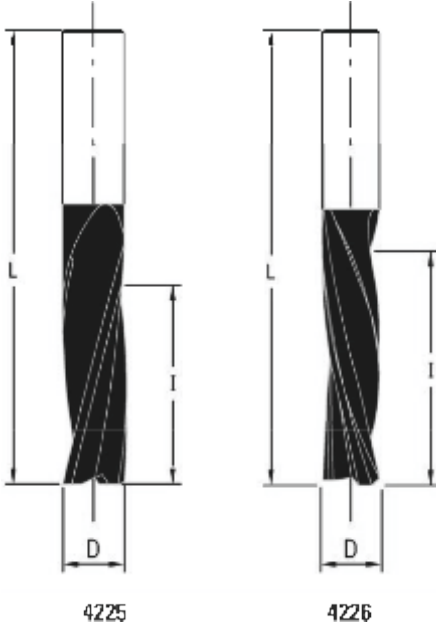

BUP DIA KAPLAMALI

- * Ahşap, sunta ve MDF panellerin ebatlama ve delme
- * Micrograin solid HW.
- * CNC Freze
- * Up - Cut; 3 adet pozitif kesici ağız ile talaşı yukarı yöne iter
- * Down - Cut; 3 adet pozitif kesici ağız ile talaşı aşağı yöne iter

RH Z = 3 UP - CUT SPIRAL

RH Z = 3 DOWN - CUT SPIRAL

KOD.	D	I	L	KOD.	D	I	L
4225 080 022	8	22	65	4226 080 022	8	22	65
4225 080 032	8	32	80	4226 080 032	8	32	80
4225 100 032	10	32	80	4226 100 032	10	32	80
4225 100 042	10	42	100	4226 100 042	10	42	100
4225 120 032	12	32	80	4226 120 032	12	32	80
4225 120 042	12	42	100	4226 120 042	12	42	100
4225 120 052	12	52	100	4226 120 052	12	52	100

4230

HM: SOLID SPIRAL FREZELER Z.3 (KABA KESİM)



BUP DIA KAPLAMALI

RH Z = 3 UP - CUT SPIRAL

- * Ahşap, sunta ve MDF panellerin ebatlama ve delme
- * Micrograin solid HW.
- * Up - Cut; 3 adet pozitif kesici ağız ile talaşı yukarı yöne iter
- * CNC Freze

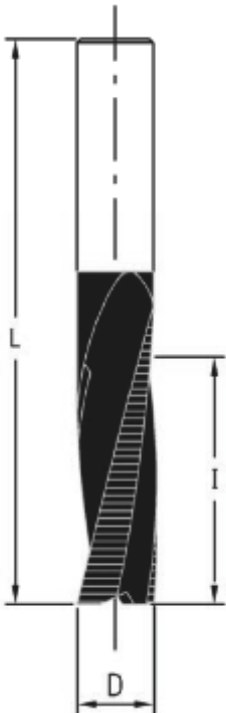

KOD.	D	I	L
4230 080 022	8	32	65
4230 080 032	8	32	80
4230 100 032	10	32	80
4230 010 042	10	42	100
4230 120 032	12	32	80
4230 120 042	12	42	100
4230 120 052	12	52	100
4230 140 042	14	42	100
4230 140 052	14	52	100
4230 160 042	16	42	90
4230 160 052	16	52	100

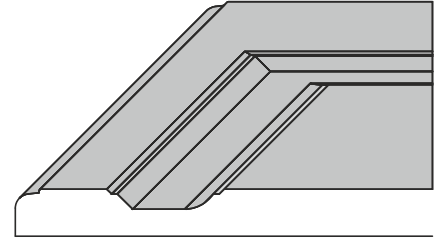
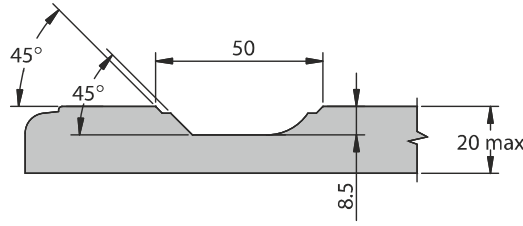
5001**HM: CNC MDF KAPAK FREZELERİ**

KOD.	D	S	RPM Max.	Profil	Z	Jilet Bıçak
5001 000 001	65	40	16.000	A	2	8170 040 035
5001 000 002	50	25	18.000	B	2	8170 030 025
5001 000 003	24	25	20.000	C	1	8170 025 012
5001 000 004	24	25	20.000	D	1	8125 025 012

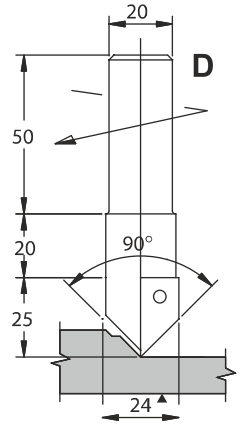
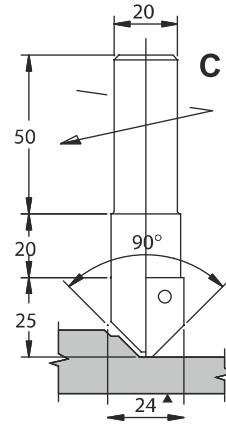
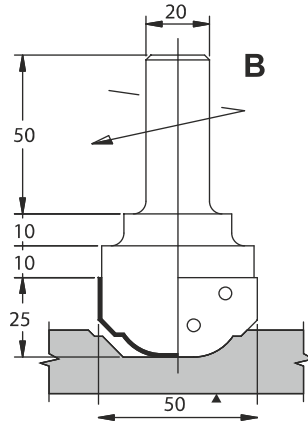
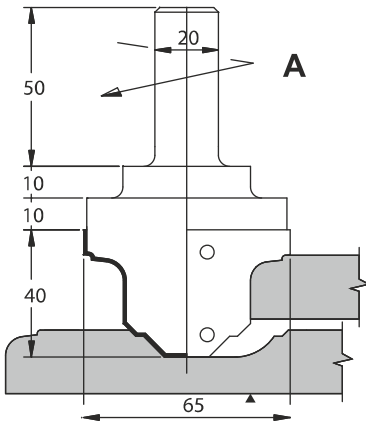
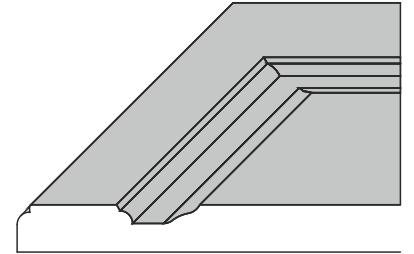
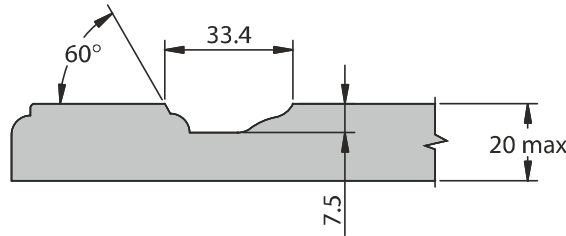
**5002****HM: CNC MDF KAPAK FREZELERİ**

KOD.	D	S	RPM Max.	Profil	Z	Jilet Bıçak
5002 000 001	60	35	16.000	A	2	8170 035 035
5002 000 002	30	20	20.000	B	2	8170 015 020
5002 000 003	24	25	20.000	C	1	8170 025 012
5002 000 004	24	20	20.000	D	1	8125 020 012

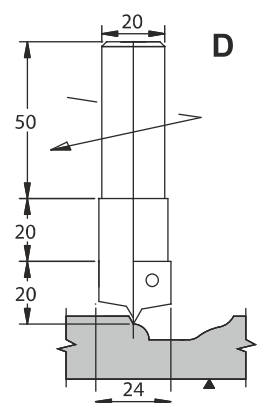
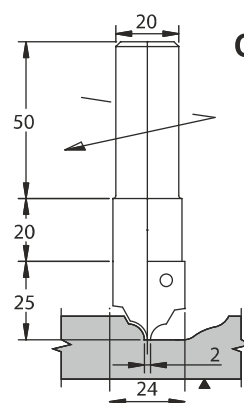
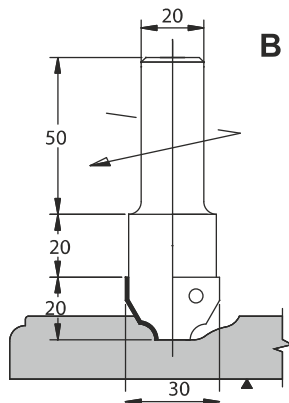
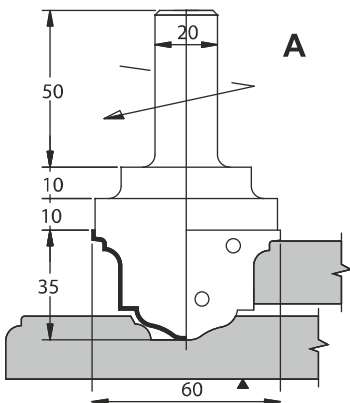

5003

HM: CNC MDF KAPAK FREZELERİ

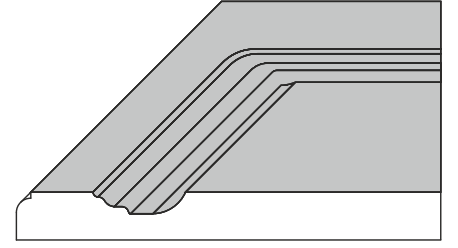
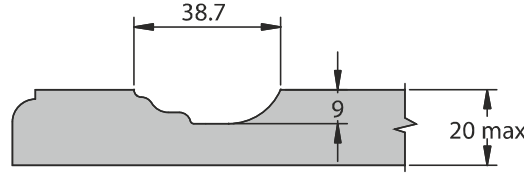

KOD.	D	S	RPM Max.	Profil	Z	Jilet Bıçak
5003 000 001	50	35	18.000	A	2	8170 035 025
5003 000 002	30	25	20.000	B	2	8170 015 025

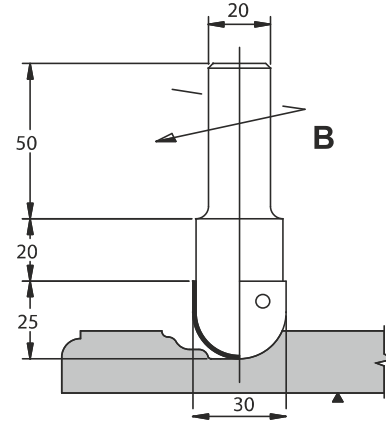
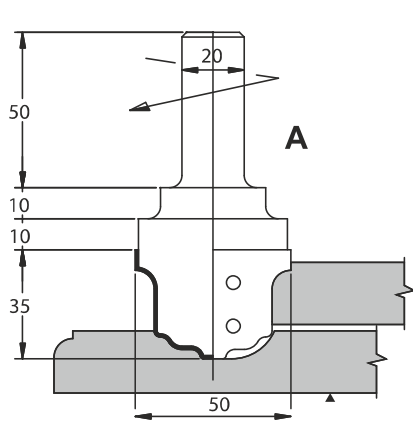

5004

HM: CNC MDF KAPAK FREZELERİ

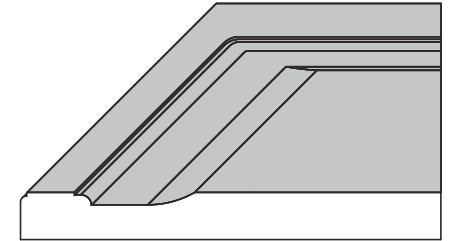
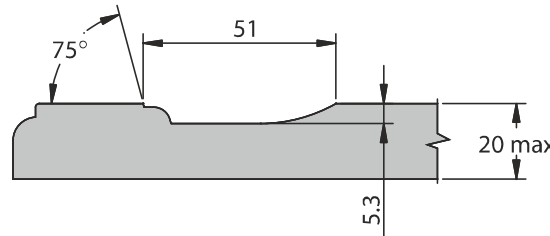

KOD.	D	S	RPM Max.	Profil	Z	Jilet Bıçak
5004 000 001	60	30	18.000	A	2	8170 030 030
5004 000 002	50	25	18.000	B	2	8170 030 025
5004 000 003	40	20	20.000	C	2	8170 020 020
5004 000 004	24	20	20.000	D	2	8170 020 012

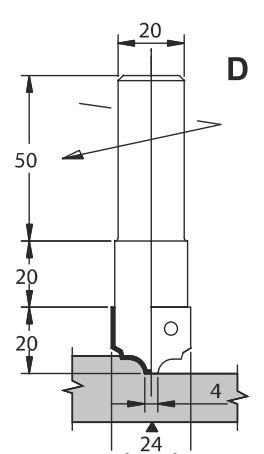
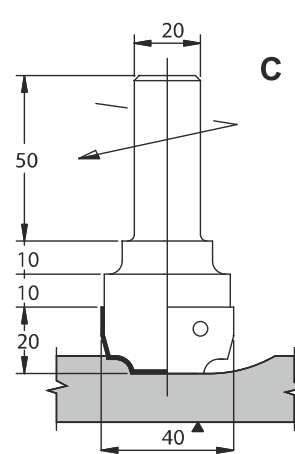
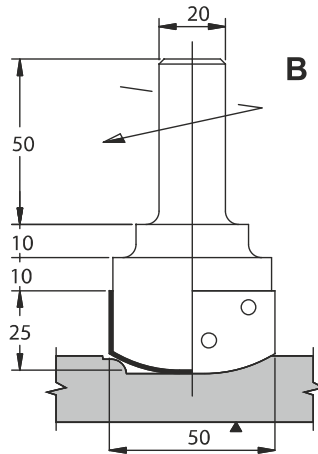
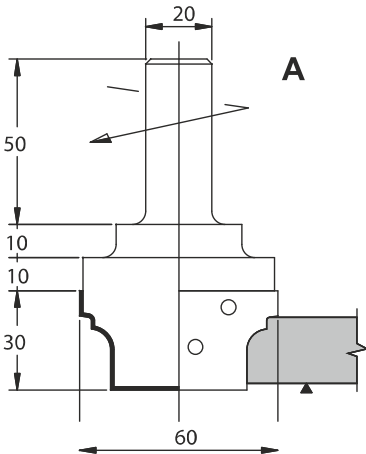

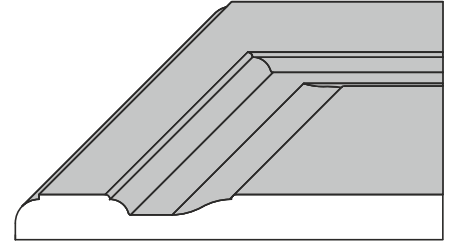
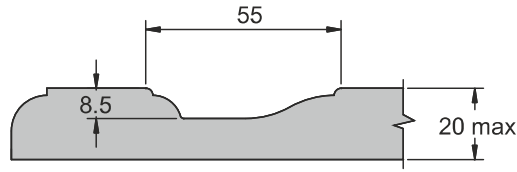
5005**HM: CNC MDF KAPAK FREZELERİ**

KOD.	D	S	RPM Max.	Profil	Z	Jilet Bıçak
5005 000 001	70	35	16.000	A	2	8170 035 035
5005 000 002	60	25	18.000	B	2	8170 030 025
5005 000 003	30	25	20.000	C	2	8170 015 025
5005 000 004	24	20	20.000	D	2	8125 020 012

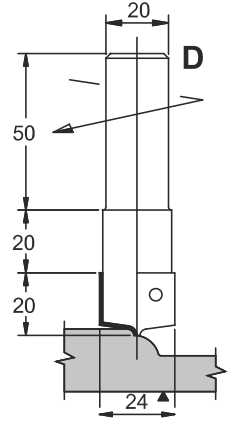
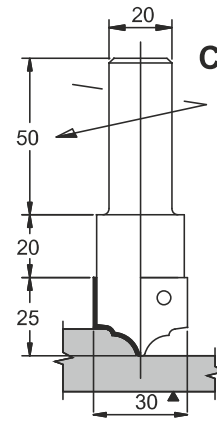
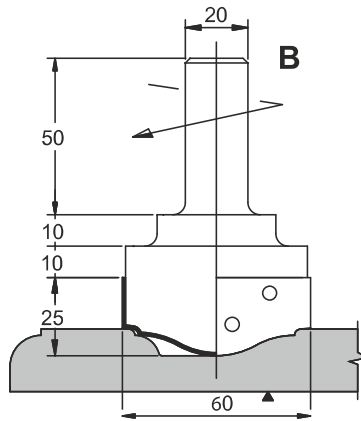
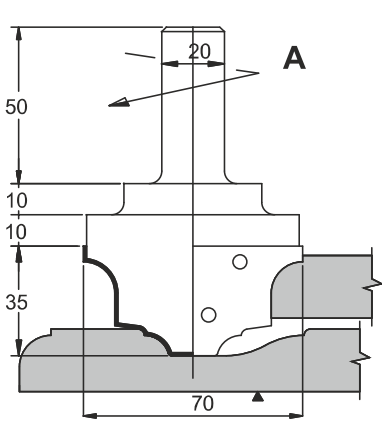
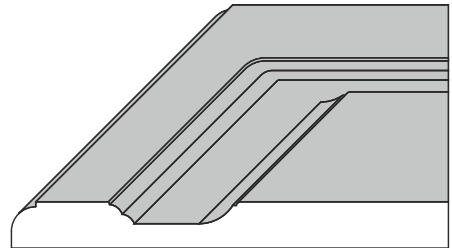
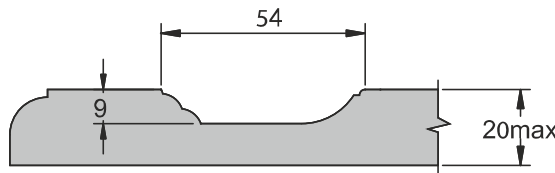
**5006****HM: CNC MDF KAPAK FREZELERİ**

KOD.	D	S	RPM Max.	Profil	Z	Jilet Bıçak
5006 000 001	60	40	18.000	A	2	8170 040 040
5006 000 002	60	25	18.000	B	2	8170 030 025
5006 000 003	30	25	20.000	C	2	8170 015 025

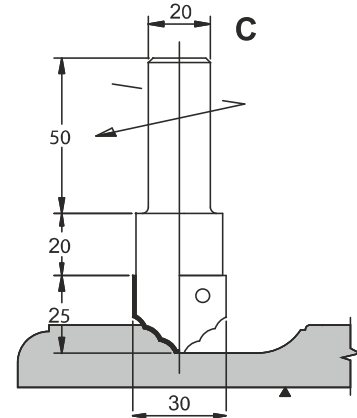
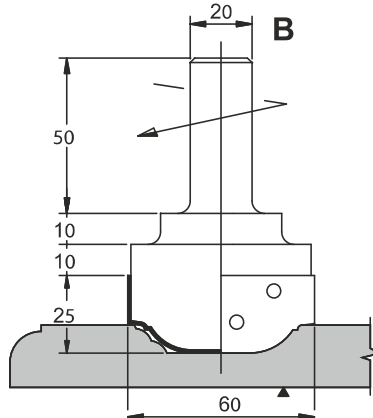
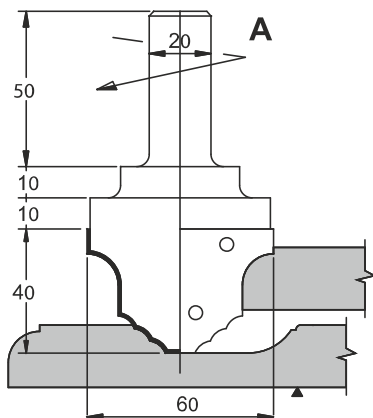

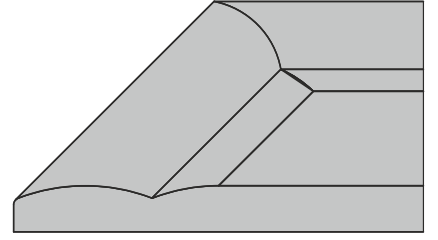
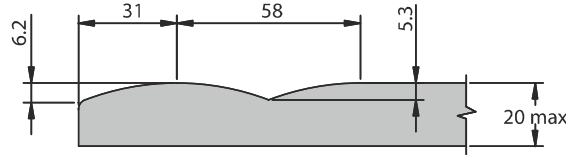
5007**HM: CNC MDF KAPAK FREZELERİ**

KOD.	D	S	RPM Max.	Profil	Z	Jilet Bıçak
5007 000 001	110	50	12.000	A	2	8170 050 030
5007 000 002	70	25	18.000	B	2	8170 035 025

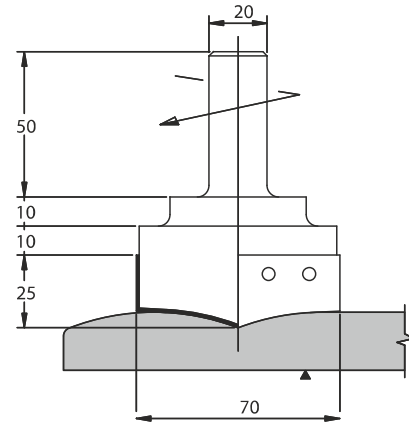
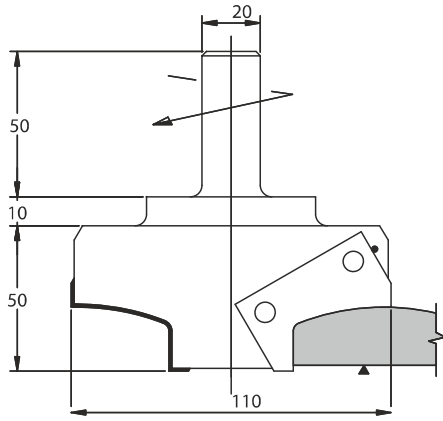
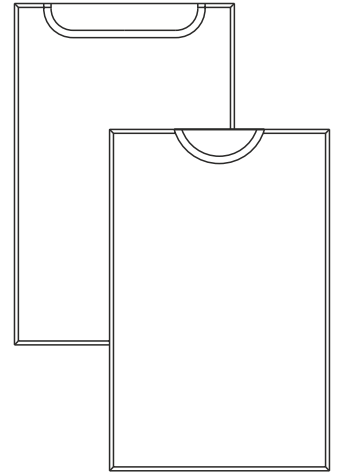
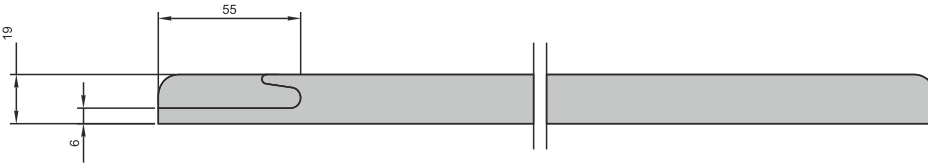
**5403****HM: CNC MDF KAPAK FREZELERİ**

KOD. RH	D	S	RPM Max.	Profil	Z
5403 000 001	50	30	18.000	A	2
5403 000 002	60	30	16.000	B	2
6403 000 001	30	40	20.000	C	2

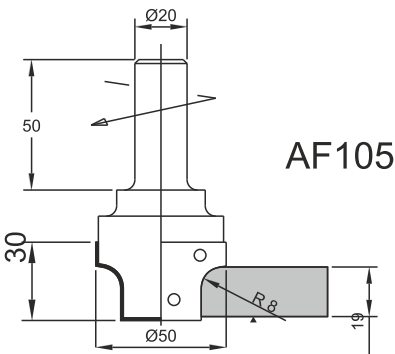

AF105

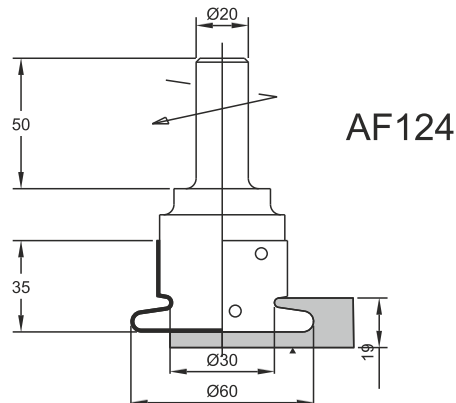

AF124

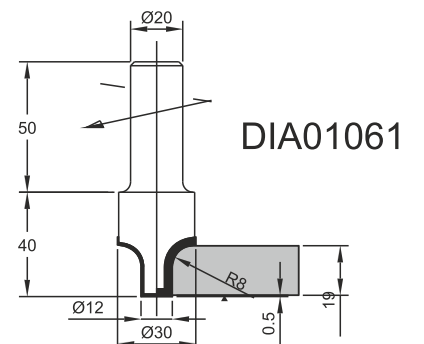

DIA01061

KOD. RH	D	S	RPM Max.	Profil	Z
5401 000 001	110	55	12.000	A	2
5401 000 002	60	30	18.000	B	2
5401 000 003	50	25	18.000	C	2
5401 000 004	40	25	18.000	D	2
5401 000 005	24	20	20.000	E	2
6401 000 001	92	40	18.000	F	2

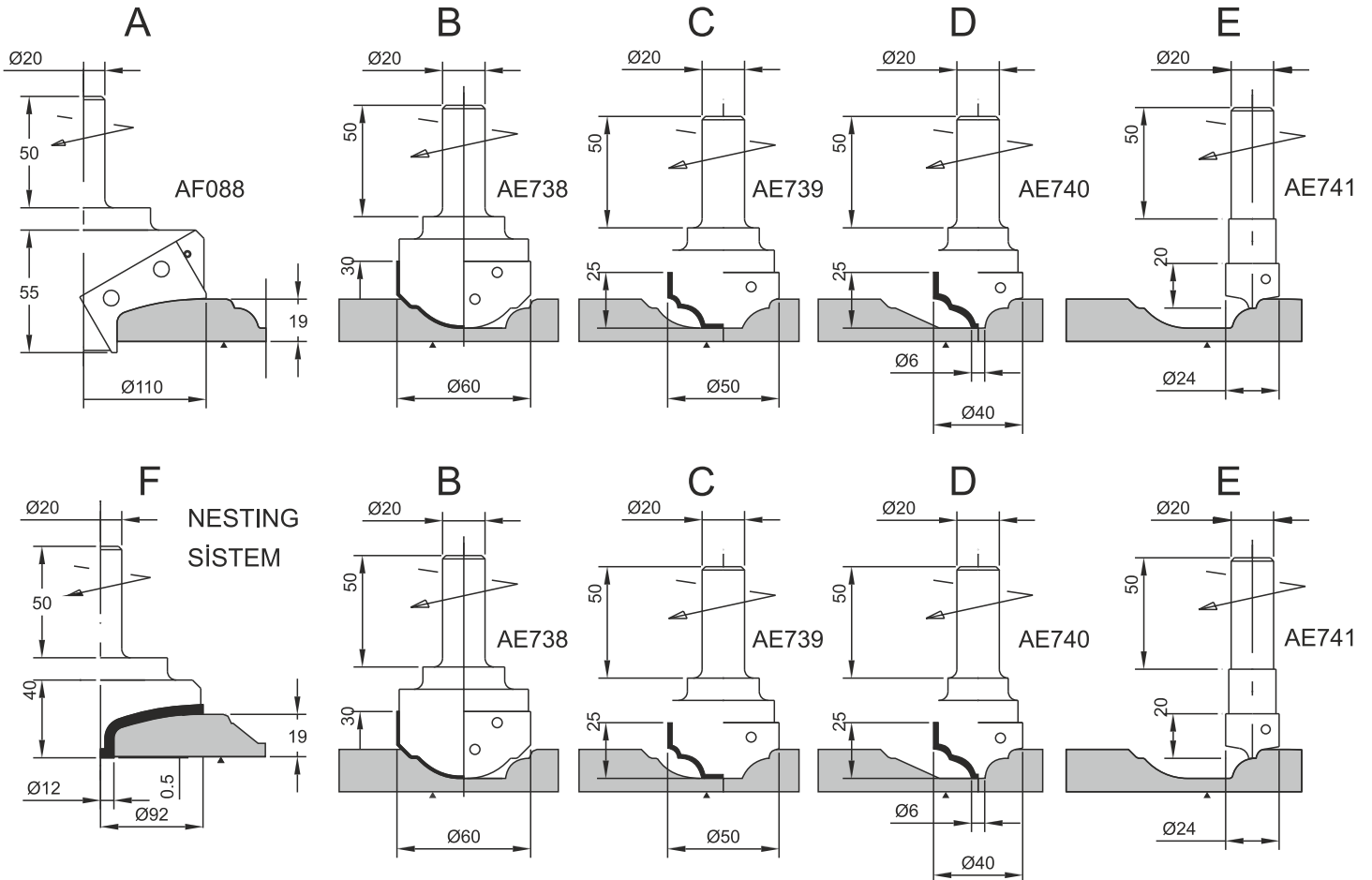
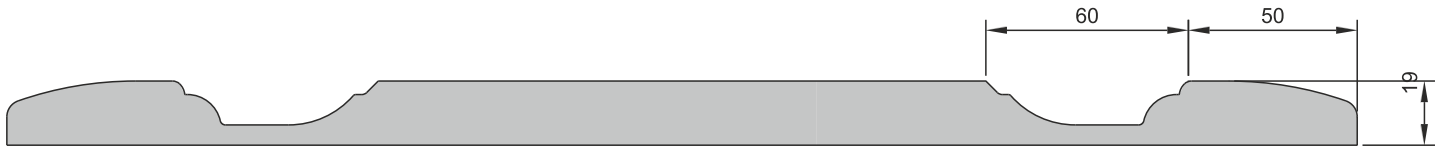
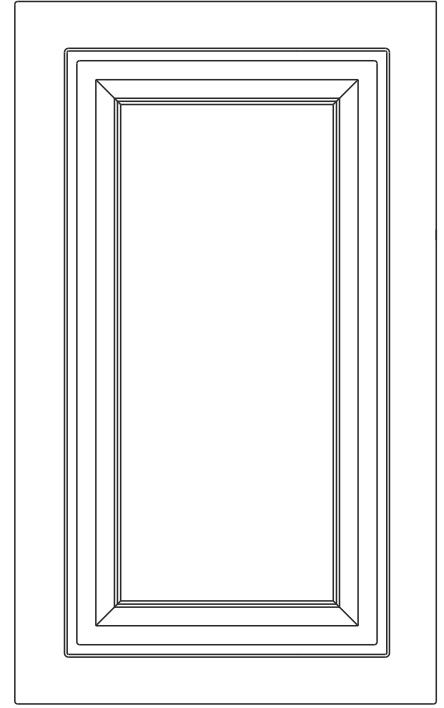

KOD. RH	D	S	RPM Max.	Profil	Z
5402 000 001	50	30	18.000	A	2
5402 000 002	52.6	25	18.000	B	2
5402 000 003	67	25	16.000	C	2
5402 000 004	41.6	25	20.000	D	2
5402 000 005	24	20	20.000	E	2
6402 000 001	25.2	23	20.000	F	2

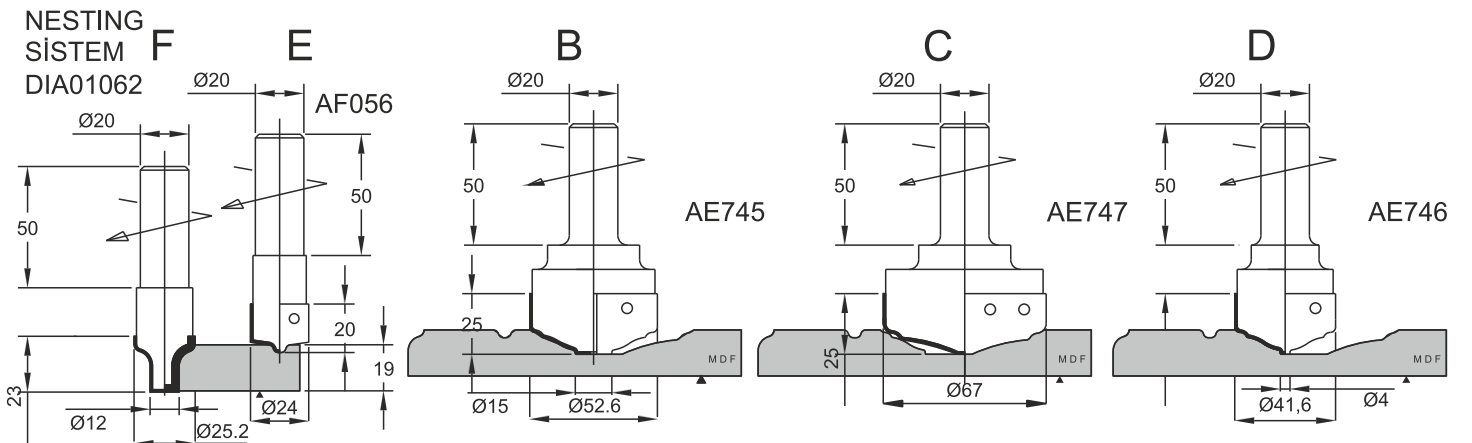
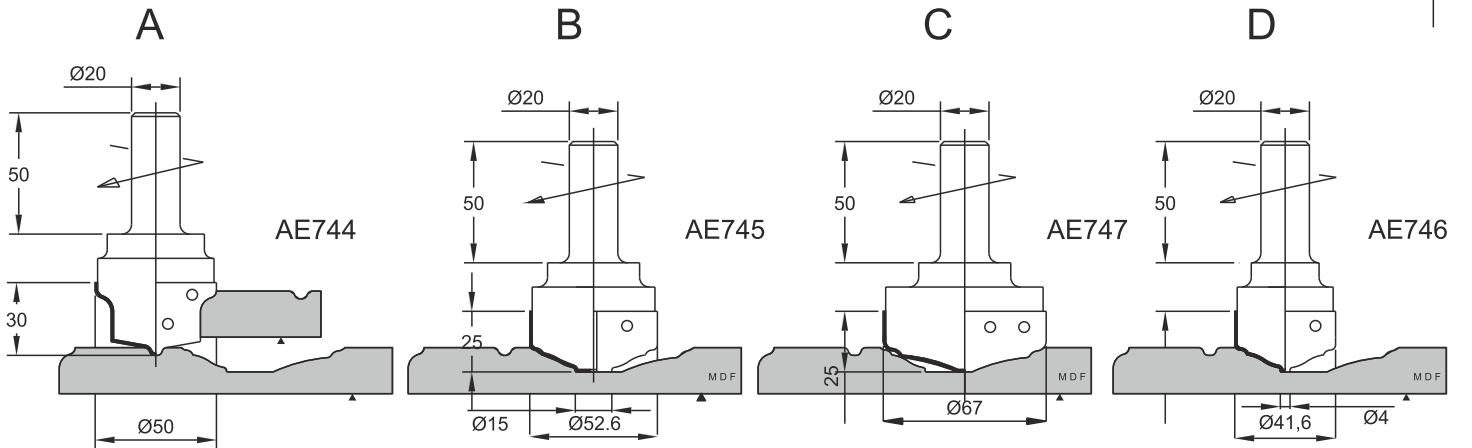
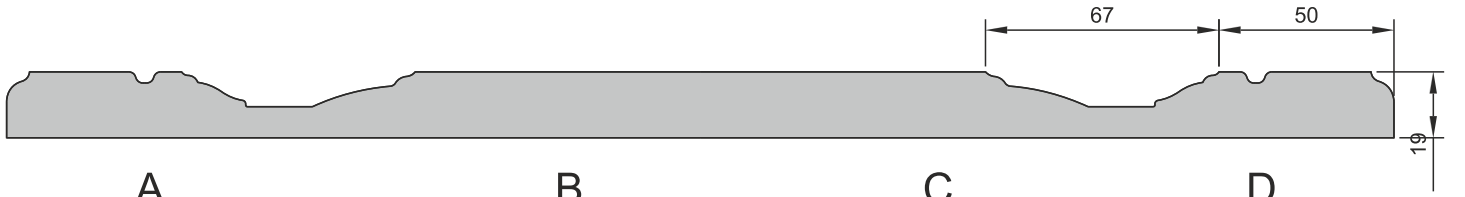
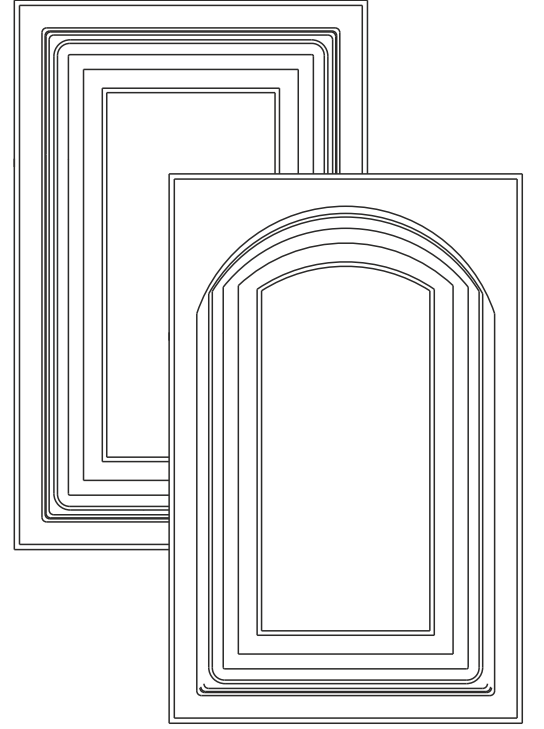

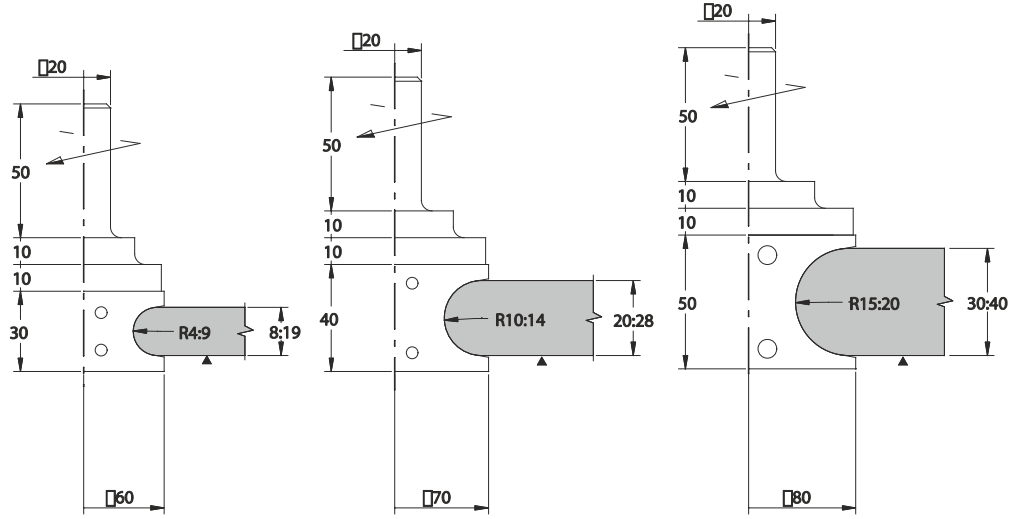
5011**HM. CNC KENAR RADIUS FREZELERİ**

KOD.	D	S	RPM Max.	H	Z	Jilet Bıçak
5011 000 001	60	30	18.000	8-19	2	8170 030 030
5011 000 002	70	40	16.000	20-28	2	8170 040 035
5011 000 003	80	50	14.000	30-40	2	8170 050 040

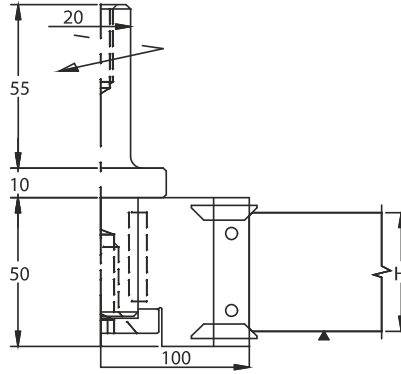
5013**HM: CNC KAPI KENARI ve RADIUS FREZELERİ**

*Hafif alaşımlı ergal gövde

*Ayarlanabilir R1,5 - R2 - R3 ve 45° Köşe

KOD.	D	S	RPM Max.	H Max.	Z	Jilet Bıçak
5013 000 001	100	50	12.000	50	2+4	8105 500 012
5013 000 002	100	60	12.000	60	2+4	8105 600 012

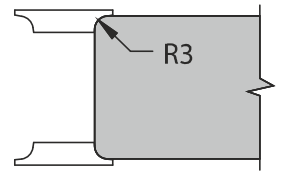
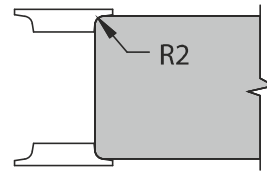
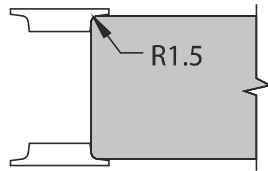
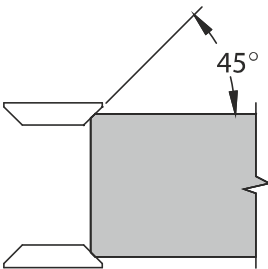

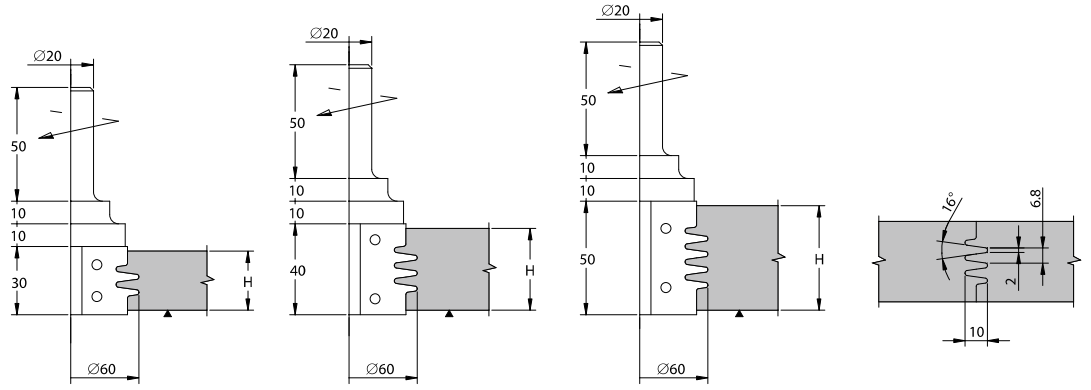
5017**CNC FINGER JOINT FREZE**

KOD.	D	S	H	RPM Max.	Z	Jilet Bıçak
5017 000 001	60	30	18÷26	18.000	2	8230 030 010
5017 000 002	60	40	26÷36	18.000	2	8230 040 010
5017 000 003	60	50	33÷46	18.000	2	8230 050 010

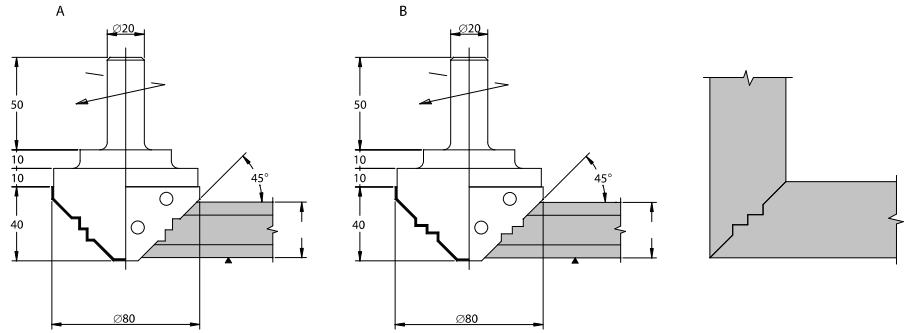
5018**45° KÖŞE BİRLEŞTİRME CNC FREZE**

KOD.	D	S	H	RPM Max.	Z	Jilet Bıçak
5018 000 001	80	40	16÷30	16.000	2	8170 040 040
5018 000 002	80	40	16÷30	16.000	2	8170 040 040

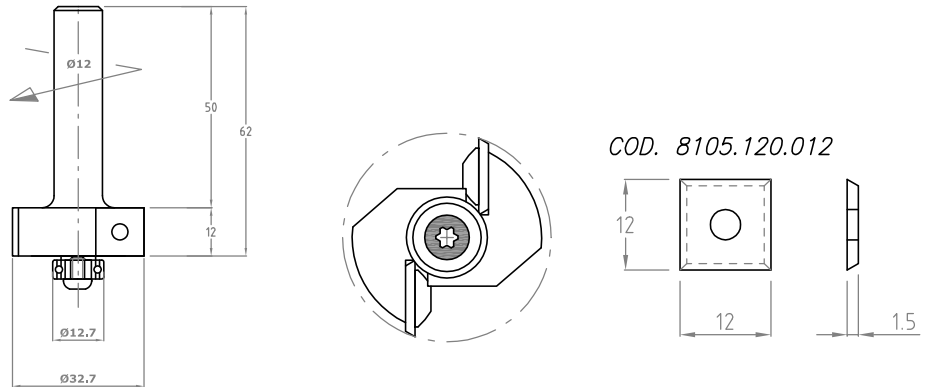
5065**CNC CAM YERİ AÇMA FREZESİ**

KOD.	D	S	d	RPM Max.	Z	Jilet Bıçak
5065 040 012	40	12	12	12.000	2	8102 120 012
8405 127 065	12.7	4.7	6.5	RULMAN		



KOD.	D	S	RPM Max.	Z	Jilet Bıçak
5019 000 001	24	25	20.000	1	8170 025 012

*Aynı gövde üzerinde 9 farklı profil

Profil: A-B-C-D-E-F-G-H-I

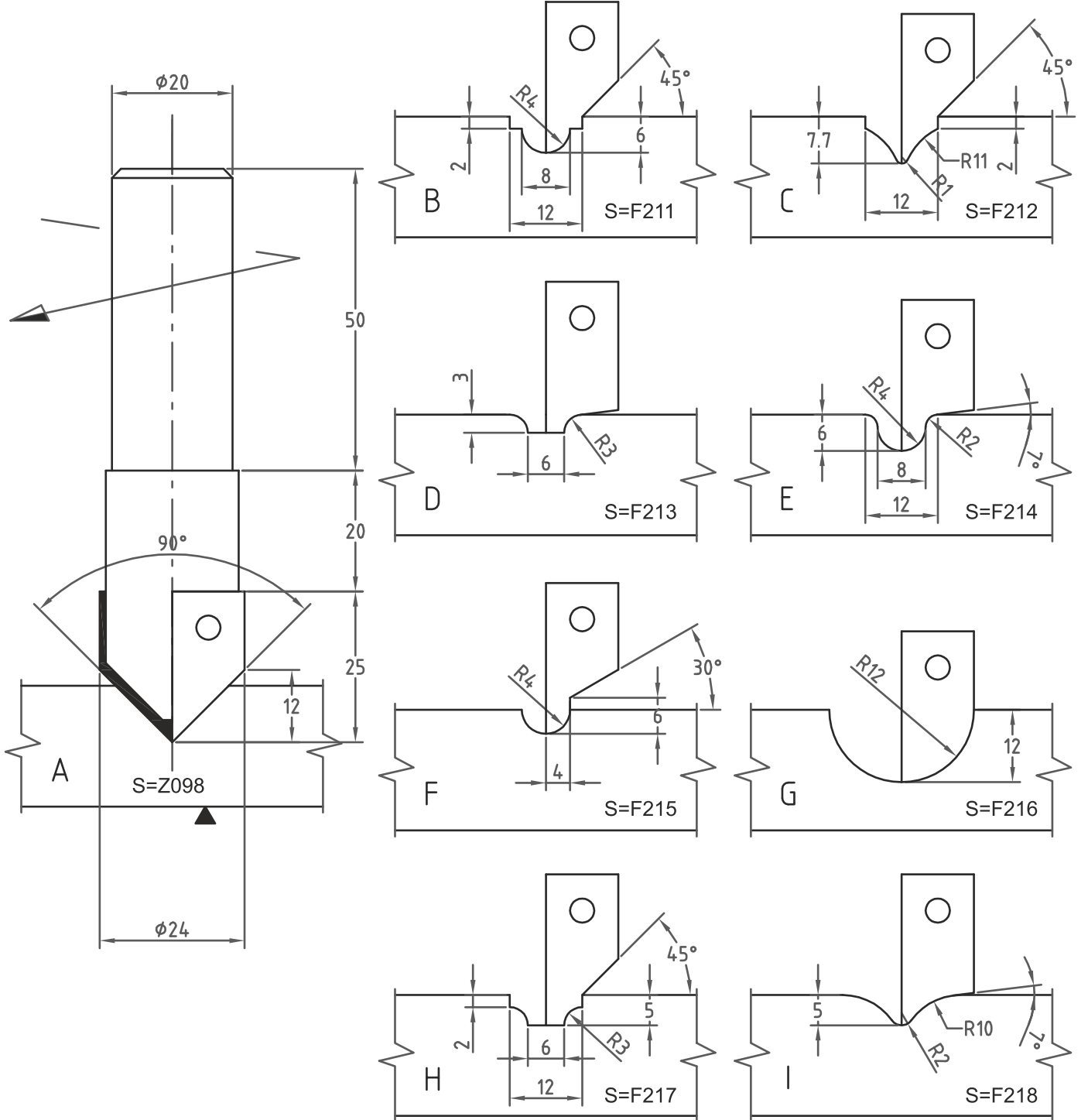

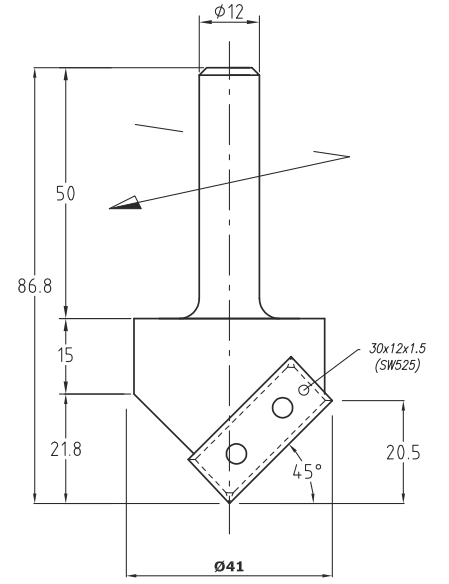
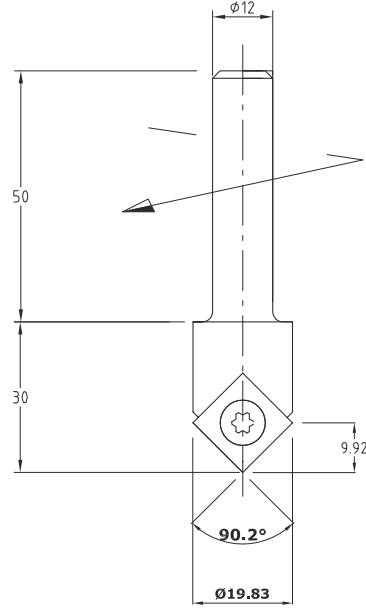
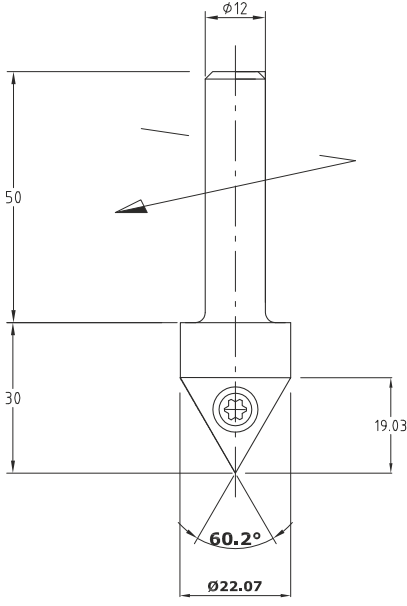

KOD.	D	S	H	AÇI	Z	Jilet Bıçak
5980 022 030	22	30	19,03	60,2°	1	8120 228 003
5980 020 030	20	30	9,92	90,2°	1	8120 140 002
5980 041 035	41	35	20,5	45°	1	8163 301 012 SW525

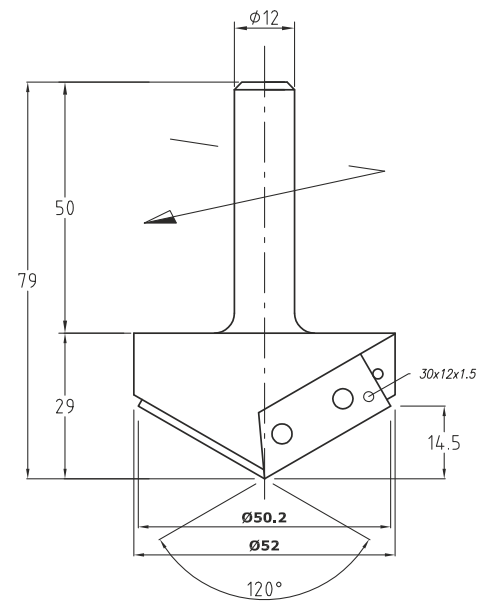
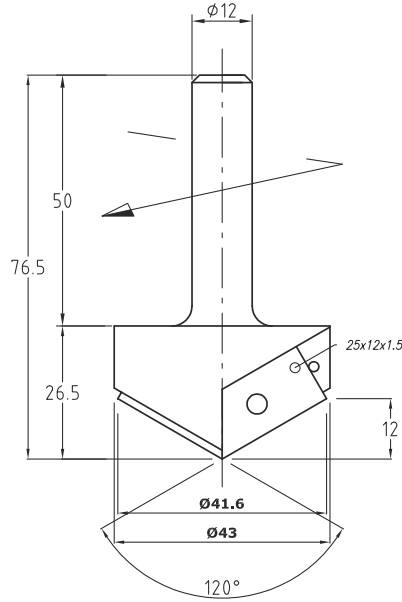
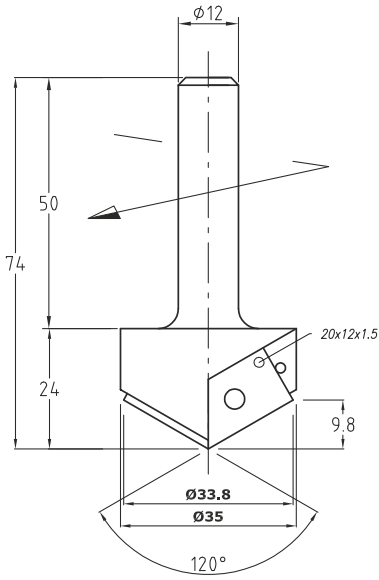

KOD.	D	S	H	AÇI	Z	Jilet Bıçak
5980 035 024	35	24	9,8	120°	2	8170 200 012
5980 043 027	43	27	12	120°	2	8170 250 012
5980 052 029	52	29	14,5	120°	2	8170 300 012

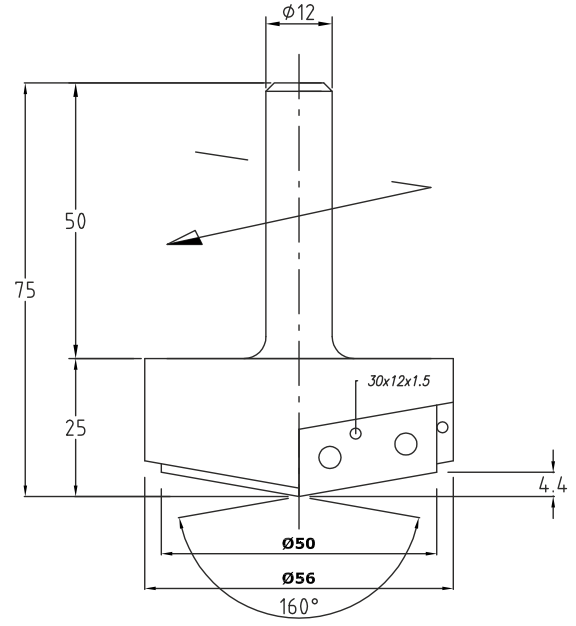
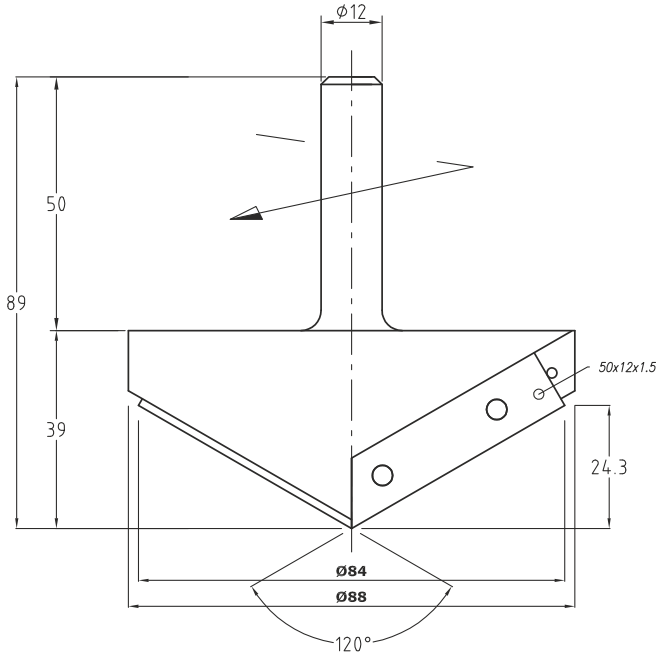

KOD.	D	S	H	AÇI	Z	Jilet Bıçak
5980 088 039	88	39	24,3	120°	2	8170 500 012
5980 056 025	56	25	4,4	160°	2	8145 300 012

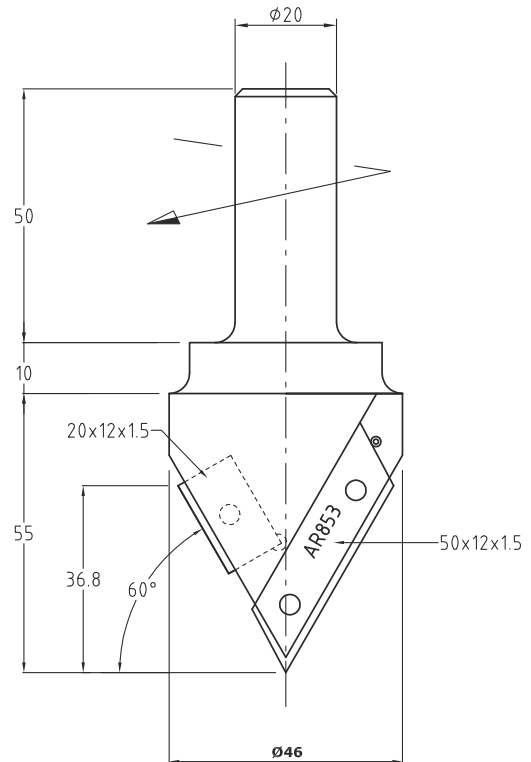
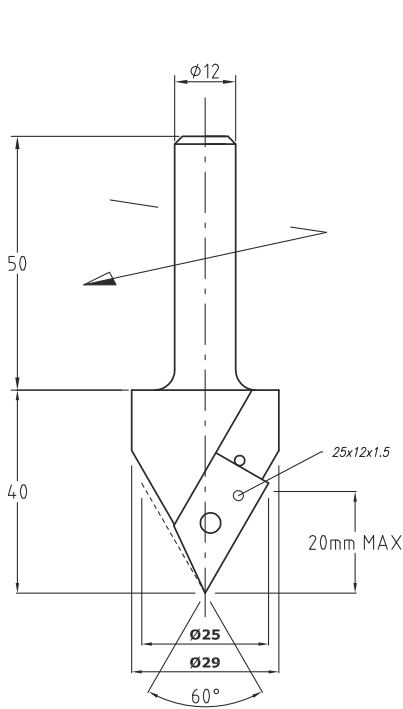

KOD.	D	S	H	AÇI	Z	Jilet Bıçak
5980 030 040	30	40	20	60°	1	8170 250 012
5046 046 055	46	55	36,8	60°	1+1	8145 500 012 AR853

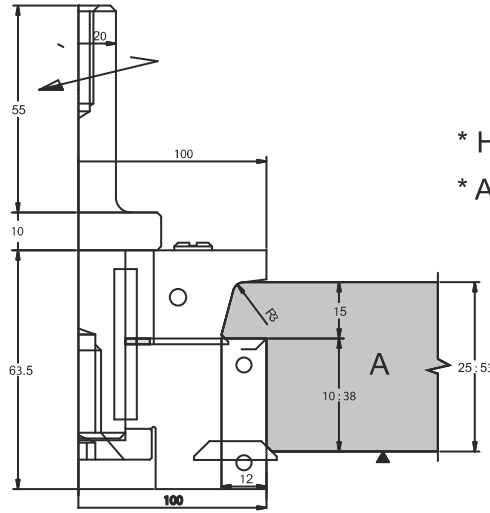
5021**HM: CNC KAPI LAMBA FREZELERİ**

* Hafif alaşımlı ergal gövde

* Aynı gövde üzerinde 4 farklı profil

KOD.	D	S	RPM Max.	Z	Profil	Jilet Bıçak
5021 000 001	100	63,5	12.000	2	A-B-C-D	8170 025 030

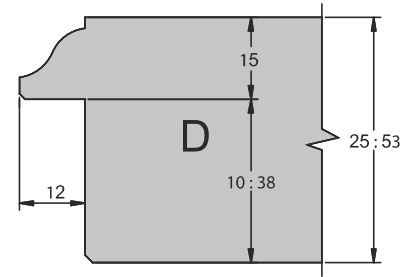
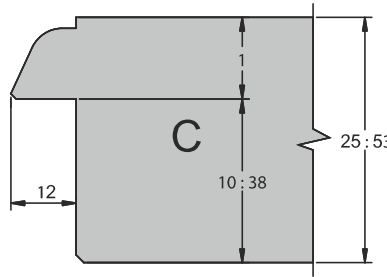
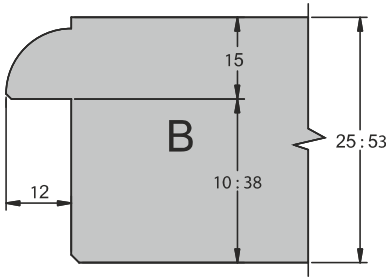
**5046****HM: CNC V KANAL FREZELERİ**

* CNC V Kesimleri



KOD.	D	S	RPM Max.	H Max.	Z	Profil	Jilet Bıçak
5046 000 001	48	35	18.000	18	1+1	A	8163 300 012
5046 000 002	60	40	18.000	25	1+1	B	8163 400 012
5046 000 003	75	50	14.000	32	1+1	C	8163 500 012

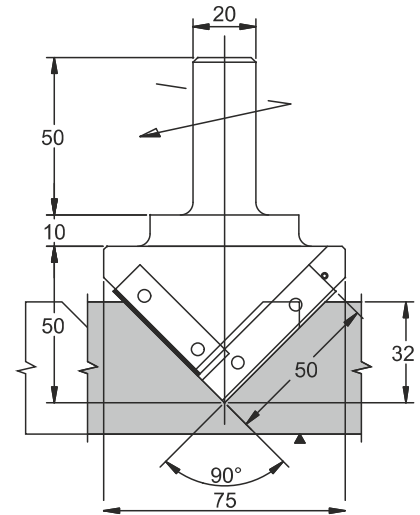
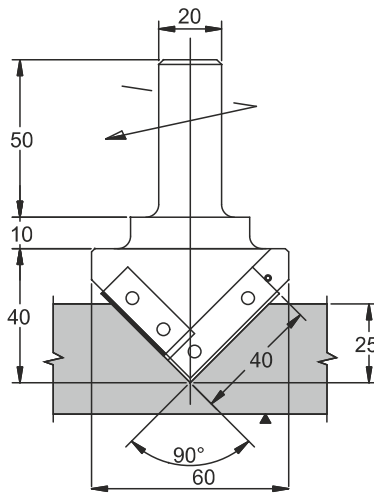
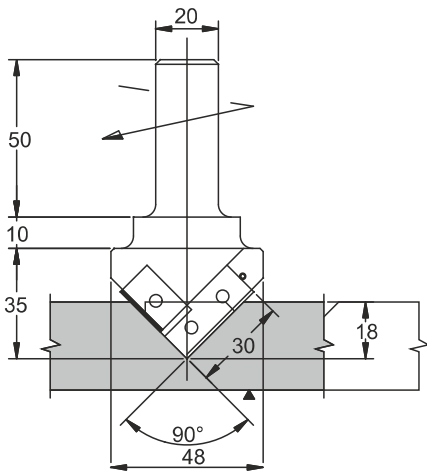

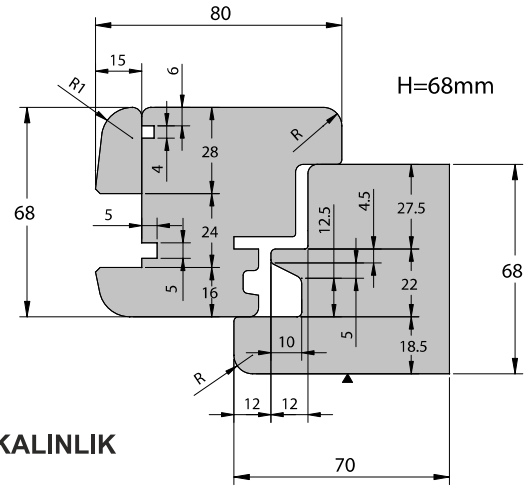
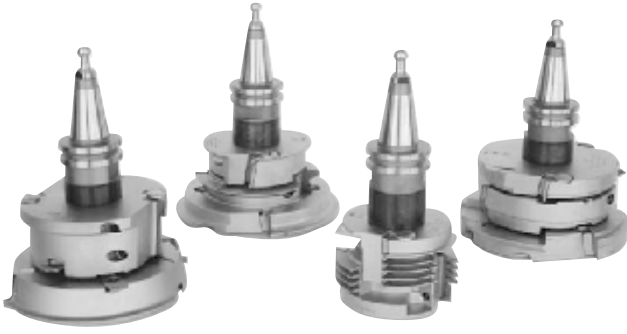

H: 68 mm. KALINLIK

KOD.	D	RPM Max.	Z	Profil	Jilet Bıçak
5024 000 001	80	12.000	2	A	8105 120 012
5024 000 002	100	12.000	2	B	8235 040 004 8235 040 004
5024 000 003	100	12.000	2	C	8235 040 004 8235 040 004
5024 000 007	160	9.000	2	D	8170 035 020 8170 025 025 8170 025 025 8130 220 015
5024 000 008	160	9.000	2	E	8170 035 030 8105 200 012 8170 025 030 8140 048 005
5024 000 009	160	9.000	2	F	8170 030 025 8170 030 020 8170 030 020 8141 048 004

ISO veya HSK tutuculu CNC kavisli ve kemerli, jilet bıçaklı pencere freze bıçakları.

A- KABA KESİM

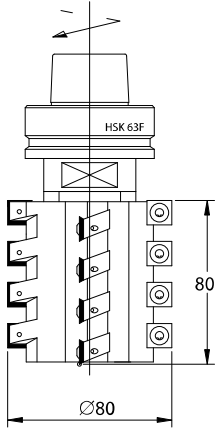

B- FINGER JOINT

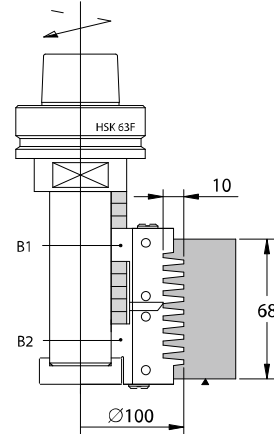

C- FINGER JOINT

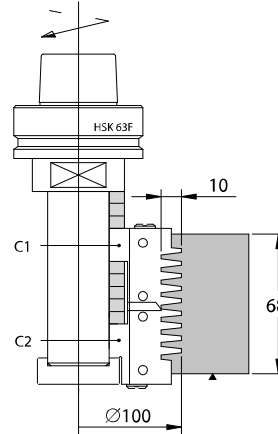

CAM ÇİTASI PROFİLİ

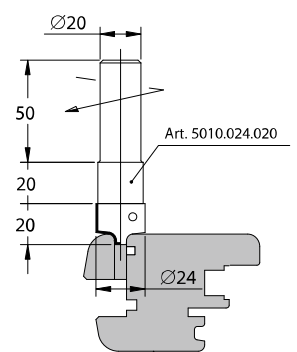

D- KASA PROFİLİ H=68

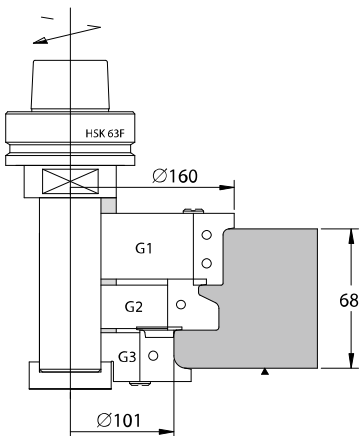

E- KANAT İÇ PROFİL H=68

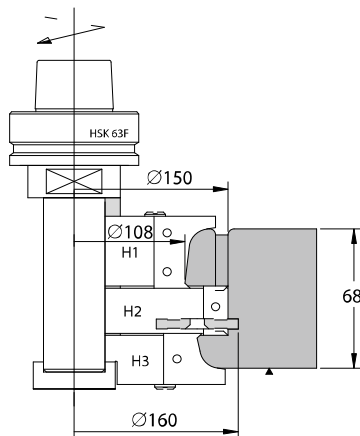

E- KANAT DIŞ PROFİL H=68

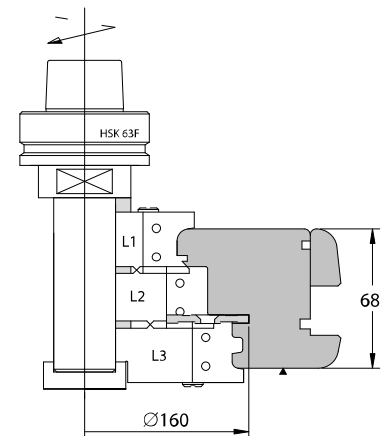

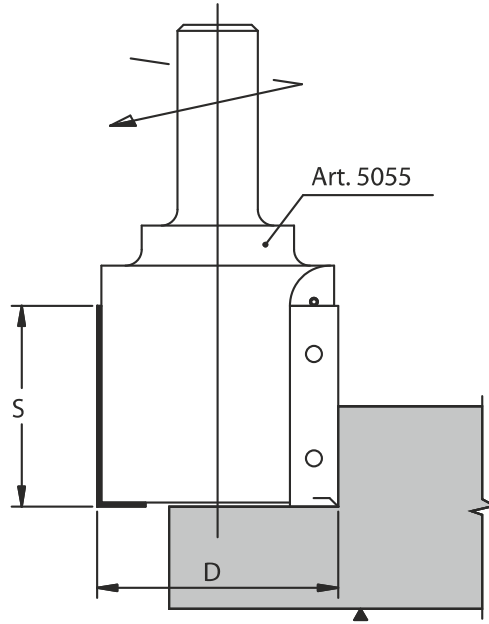
5055**HM: CNC KAPI LAMBA FREZELERİ**

- * Kenar Temizleme ve Lamba Açma Frezeleri
- * 2 Ad. Kesici ve 2 Ad. Çizici Jilet Bıçak

KOD.	D	S	d	RPM Max.	Z	Jilet Bıçak
5055 050 050	50	50	20	18.000	2+2	8105 500 012
5055 050 060	50	60	20	16.000	2+2	8105 600 012

5062**HM: CNC YÜZEY TEMİZLEME FREZELERİ**

- * Mdf Mutfak Kapakları Temizleme ve Boşaltma Frezeleri

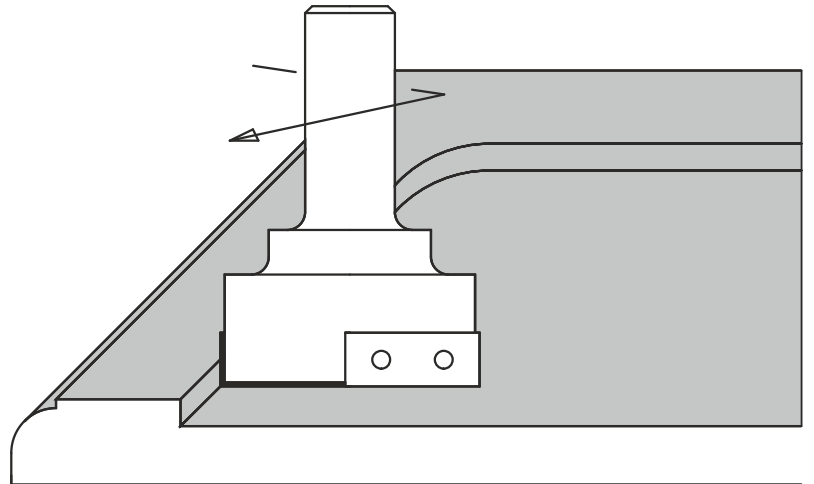
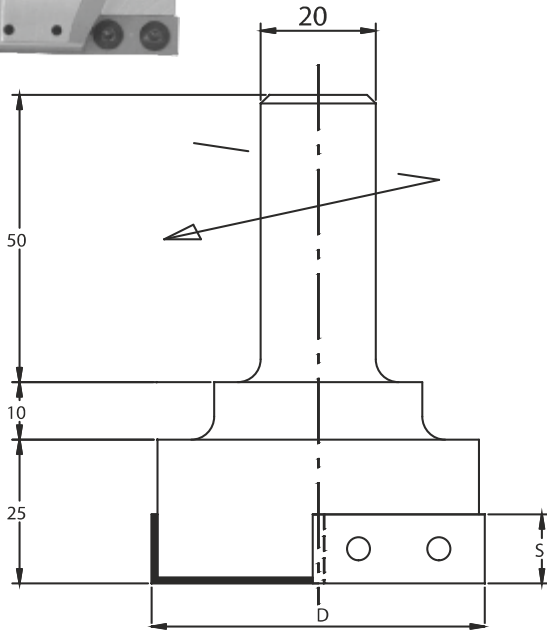

KOD.	D	S	d	RPM Max.	Z	Jilet Bıçak
5062 038 052	38	12	20	18.000	2	8162 200 012
5062 058 012	58	12	20	18.000	2	8162 300 012
5062 078 012	78	12	20	16.000	2	8162 400 012

5065**HM: CNC EBATLAMA FREZELERİ**

* Kaplamalı yada Kaplamasız Sunta, MDF,
Ahşap Panel Ebatlama Frezesi
* Z 2

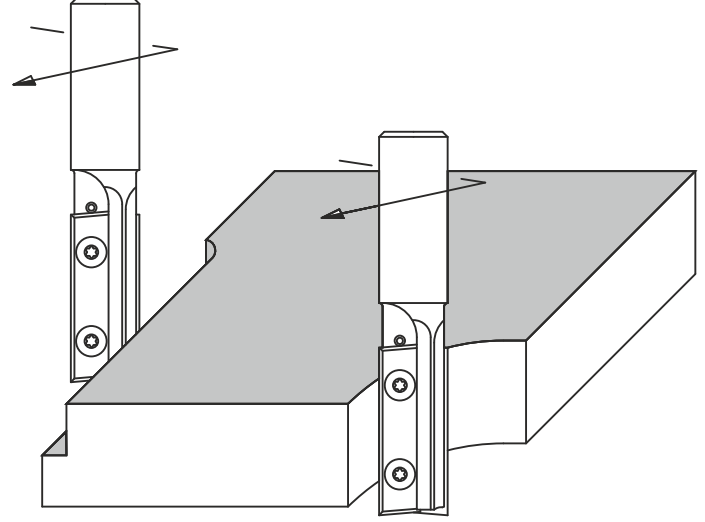
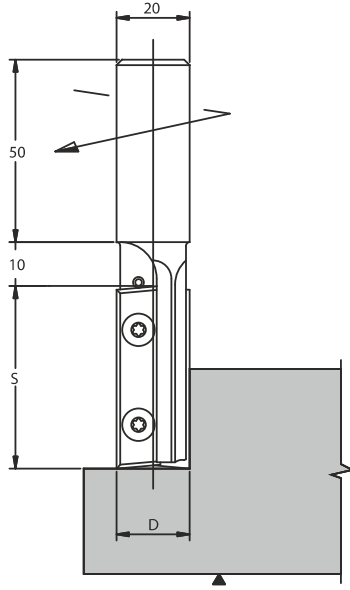

KOD.	D	S	d	RPM Max.	Z	Jilet Bıçak
5065 020 050	20	50	20	20.000	2	8145 500 012
5065 020 060	20	60	20	20.000	2	8145 600 012

5080**HM: CNC EBATLAMA FREZELERİ**

* Kaplamalı yada Kaplamasız Sunta, MDF,
Ahşap Panel Ebatlama ve Delik Frezesi
* Z 1

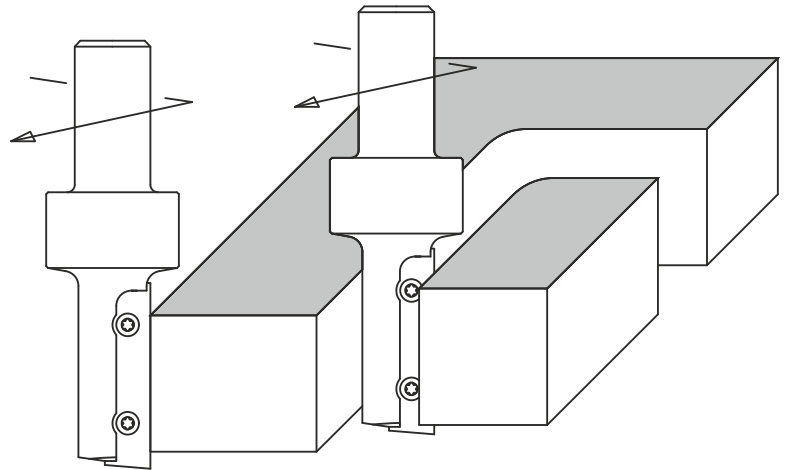
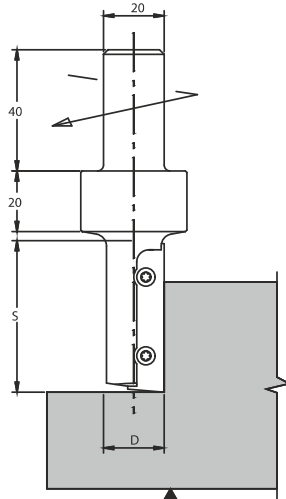

KOD.	D	S	d	RPM Max.	Z	Jilet Bıçak
5080 012 030	12	23	20	24.000	1	8150 300 009
5080 014 030	14	23	20	24.000	1	8150 300 009
5080 016 030	16	30	20	20.000	1	8145 300 012
5080 018 050	18	50	20	20.000	1	8145 500 012
5080 020 060	20	60	20	20.000	1	8145 600 012

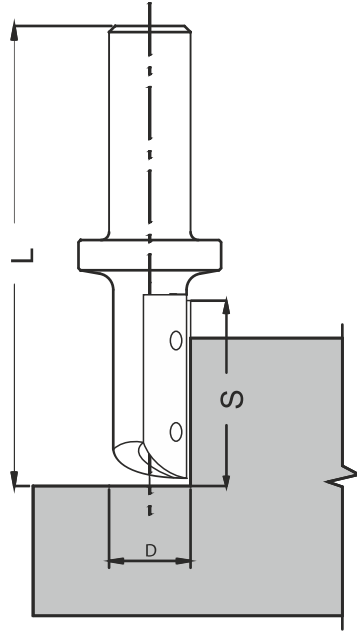
5080**HM: CNC KANAL AÇMA FREZELERİ**

* Suntalam ve mdf panellere
8-9-10 mm kanal açma ve
arkalık kanalı açılması için kullanılır

KOD.	D	S	d	RPM Max.	Z	Jilet Bıçak
5080 080 020	08	20	10	24.000	1	8115 200 041
5080 090 020	09	20	10	24.000	1	8115 200 041
5080 100 025	10	25	10	24.000	1	8115 250 055

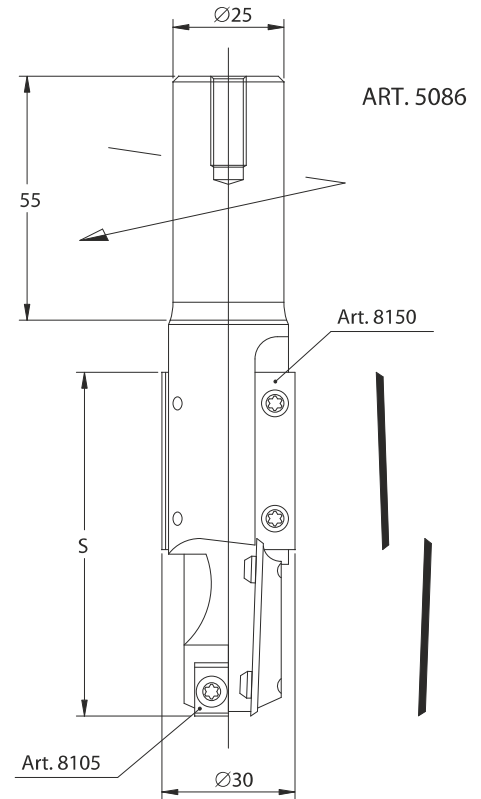
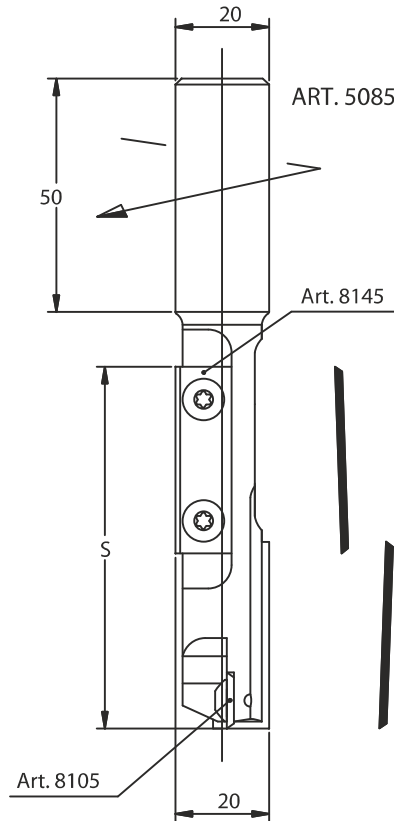
5085 - 5086**HM: CNC EBATLAMA FREZELERİ**

KOD.	D	S	d	RPM Max.	Z	Jilet Bıçak	Jilet Bıçak
5085 020 060	20	58	20	20.000	1+1+1	8145 300 012	8105 096 012
5085 020 080	20	78	20	20.000	1+1+1	8145 400 012	8105 096 012
5086 030 080	30	75	25	20.000	2+2+2	8150 400 009	8105 076 012

Freze Biçakları

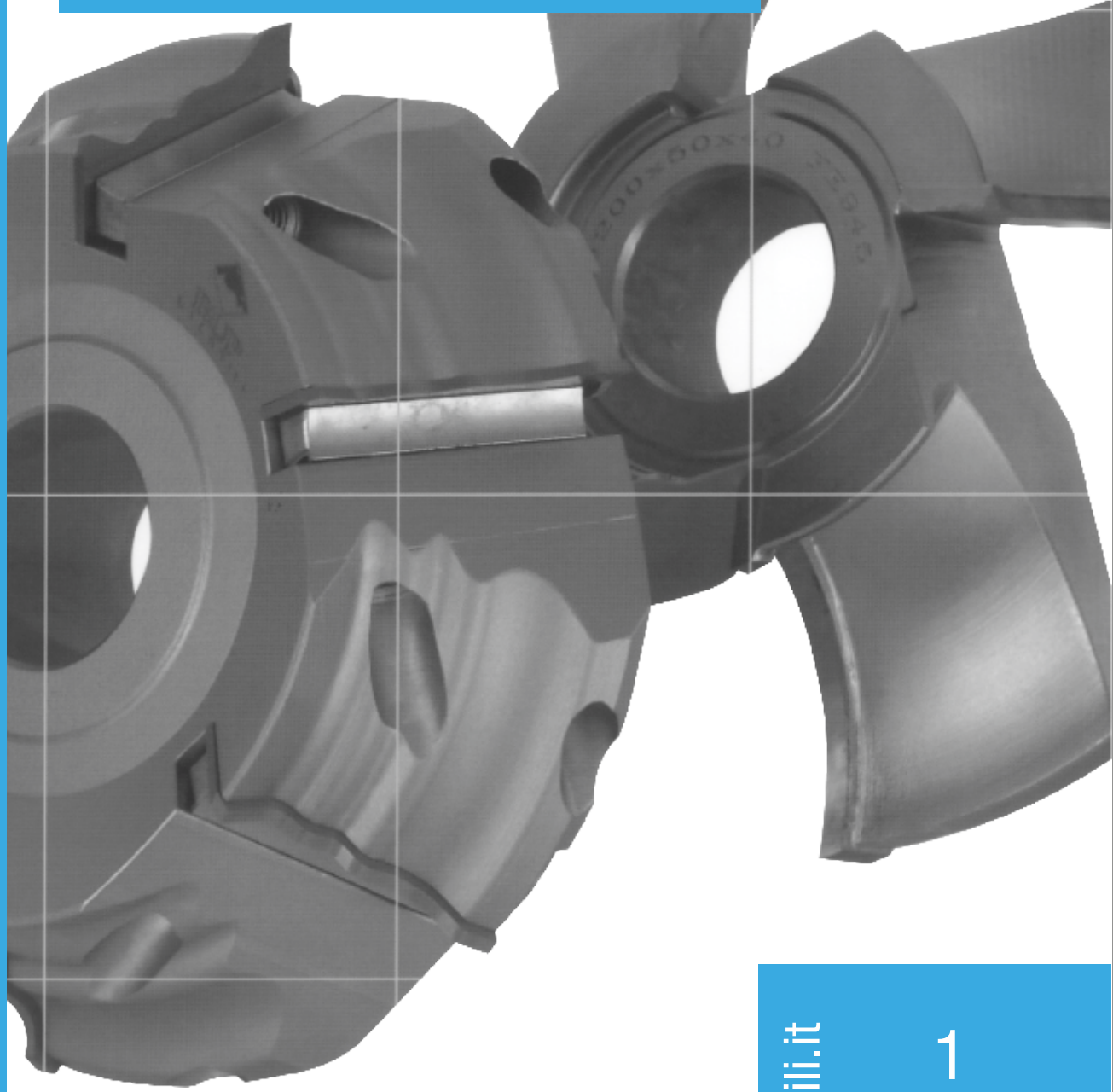

BUP[®]
UTENSILI

www.buputensili.it

3 2 1

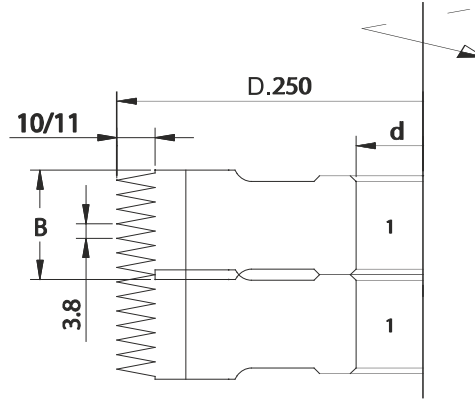
1745**HM-HSS FINGER JOINT EKLEME**

B=28,6 mm.

Max. Ağaç Kalınlığı

24	1
51	2
77	3
104	4
131	5
157	6
187	7
210	8
237	9
264	10

*** Değişebilir uçlu ve "PVD kaplamalı" HSS-HM kesiciler**

KOD.	D	B	P	Z	RPM Max.	Kalite
1745 250 002	250	28,6	10/11	6 (3+3)	6.000	HM
1745 250 003	250	28,6	10/11	8 (4+4)	6.000	HM
1745 250 004	250	28,6	10/11	6 (3+3)	6.000	HSS
1745 250 005	250	28,6	10/11	8 (4+4)	6.000	HSS
8230 284 385	HSS Değişebilir Yedek Uc					
8231 284 385	HM Değişebilir Yedek Uc					

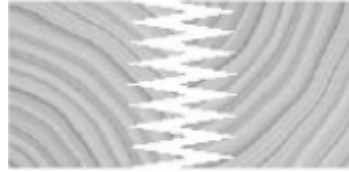
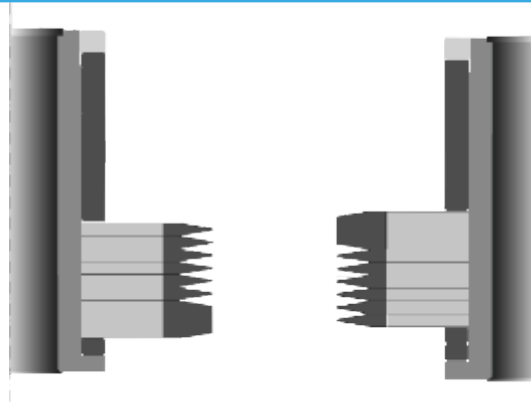
**1735****HM: FINGER JOINT EKLEME TESTERELERİ*** Üst üste dizili
finger joint testereleri

KOD.	D	B	d	P	Z	RPM Max.	Kalite
1735 149 038	149	3,8	70	10/11	4	8.300	HM
1735 160 038	160	3,8	70	10/11	4	8.300	HM
1735 160 100	160	10	70	10/11	4	8.300	HM
1735 250 038	250	3,8	70	10/11	6	6.000	HM
1735 250 114	250	10	70	10/11	6	6.000	HM



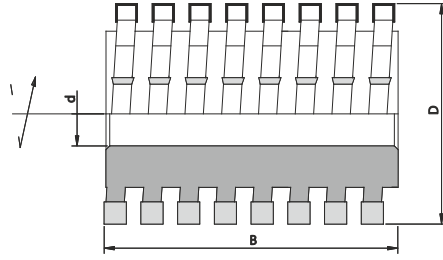

* Geniş talaş boşaltma işlemlerinde yüksek hızda kesim sağlar

* İş parçasında temiz yüzeyler sağlar

* Z=8 / Z=12 / Z=16

KOD.	D	B	d	Z	Kalite
1765 100 080	100	80	30-40	12	HM
1765 100 100	100	100	30-40	12	HM
1765 100 120	100	120	30-40	12	HM
1765 120 080	120	80	30-40	12	HM
1765 120 100	120	100	30-40	12	HM
1765 120 120	120	120	30-40	12	HM
1770 100 080	100	80	30-40	16	HM
1770 100 100	100	100	30-40	16	HM
1770 100 120	100	120	30-40	16	HM
1770 120 080	120	80	30-40	16	HM
1770 120 100	120	100	30-40	16	HM
1770 120 120	120	120	30-40	16	HM

2195

HSS ve HM PLANYA FREZELERİ

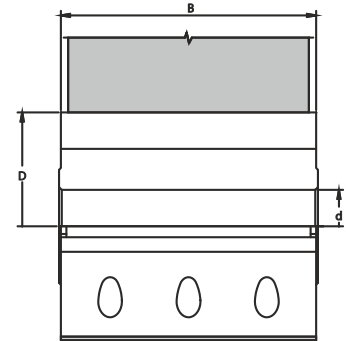
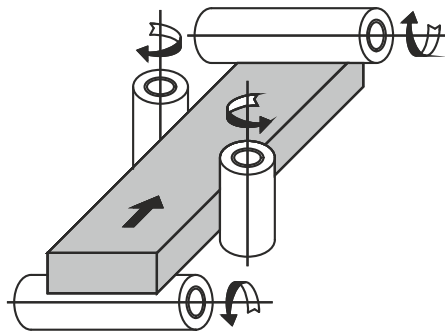

* Hafif Alaşımli ERGAL Gövde * HSS ve HM Planya Bıçaklar İle Kullanılır.

KOD.	D	B	d	RPM Max.	Z	Jilet Bıçak
2195 125 100	125	100	40	7.000	4	8005 / 8015
2195 125 120	125	120	40	7.000	4	8005 / 8015
2195 125 130	125	130	40	7.000	4	8005 / 8015
2195 125 140	125	140	40	7.000	4	8005 / 8015
2195 125 150	125	150	40	7.000	4	8005 / 8015
2195 125 180	125	180	40	7.000	4	8005 / 8015
2195 125 220	125	220	40	7.000	4	8005 / 8015
2195 125 230	125	230	40	7.000	4	8005 / 8015
2195 125 240	125	240	40	7.000	4	8005 / 8015

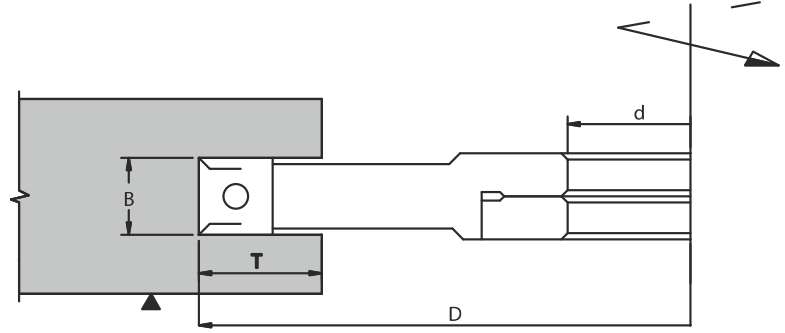
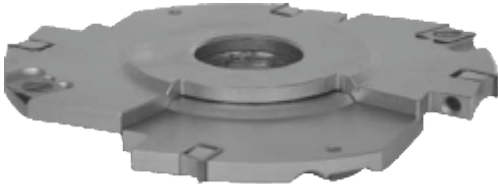

* 4 Adet Kesici ve 4 Adet Çizici Jilet Bıçak

KOD.	D	B	d	RPM Max.	Z	Jilet Bıçak
2030 160 008	160	8:15,5	30-40	5.500-9.000	4+4	8105 076 012
2030 160 012	160	12,5:24	30-40	5.500-9.000	4+4	8105 120 012
2030 160 015	160	15,5:30	30-40	5.500-9.000	4+4	8105 150 012
2030 160 030	160	30,5:60	30-40	5.500-9.000	4+4	8105 300 012

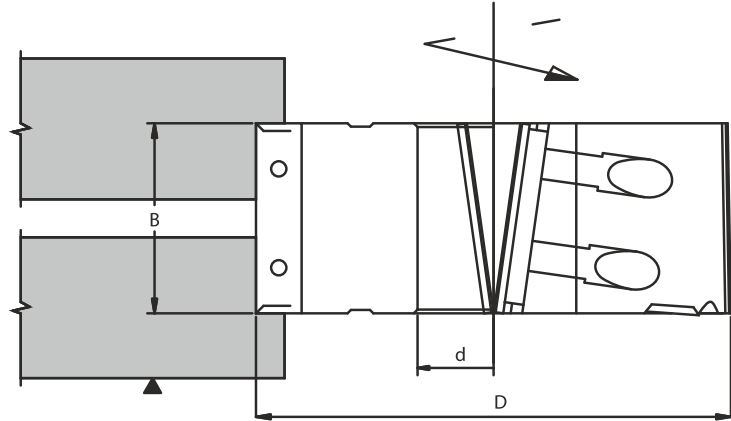

* Kenar Temizleme ve Lamba Açma Frezeleri

* 4 Adet Kesici ve 4 Adet Çizici Jilet Bıçak

KOD.	D	B	d	RPM Max.	Z	Jilet Bıçak
2105 125 030	125	30	30-50	5.300-9.200	4+4	8105 300 012
2105 125 050	125	50	30-50	5.300-9.200	4+4	8105 500 012
2105 125 060	125	60	30-50	5.300-9.200	4+4	8105 600 012
2105 150 030	150	30	30-50	5.300-9.200	4+4	8105 300 012
2105 150 050	150	50	30-50	5.300-9.200	4+4	8105 500 012
2105 150 060	150	60	30-50	5.300-9.200	4+4	8105 600 012

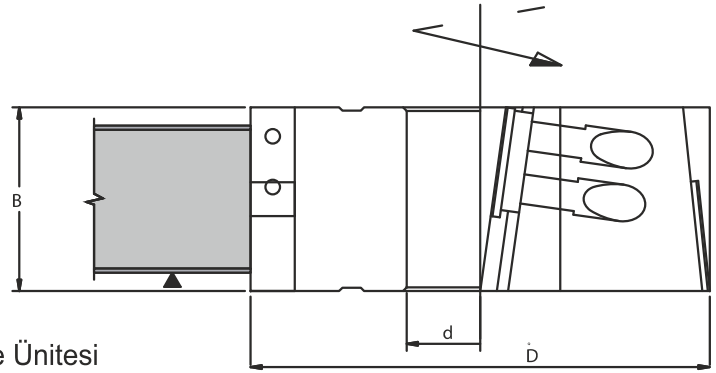

- * Kenar Bantlama Makinaları Ön Freze Ünitesi
- * Hafif Alaşım ERGAL Gövde

KOD.	D	B	Gövde	RPM Max.	Z	Jilet Bıçak
2120 100 056	100	56	Ergal Alaşım	7.000-12.000	3+3	8105 300 012
2120 125 056	125	56	Ergal Alaşım	6.000-10.500	3+3	8105 300 012
2120 150 056	150	56	Ergal Alaşım	5.200-8.900	3+3	8105 300 012
2120 180 056	180	56	Ergal Alaşım	4.000-8.000	3+3	8105 300 012

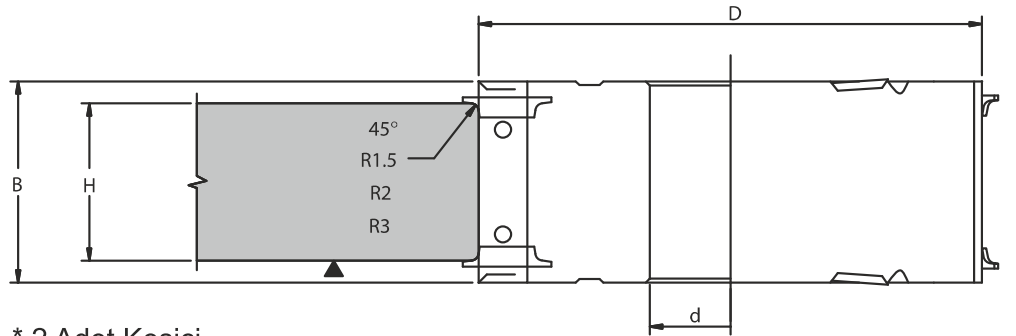
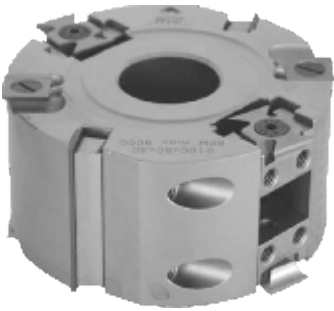

- * 2 Adet Kesici,
- 4 Adet Çizici ve
- 4 Adet Radius Jilet Bıçak

KOD.	D	B	H	d	RPM Max.	Z	Jilet Bıçak
2150 125 050	125	50	45	Max. 50	6.000-11.000	2+4+4	8105 500 012

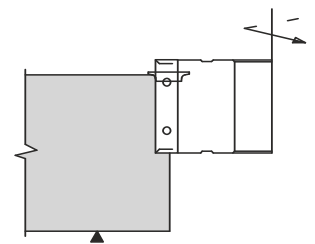
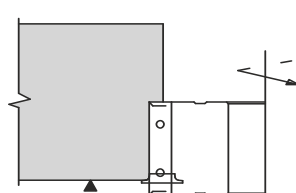
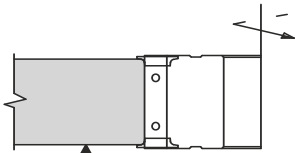
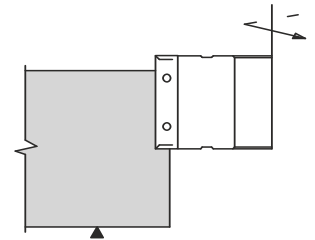
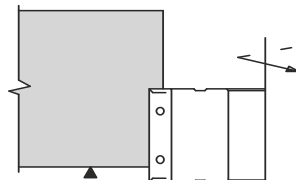
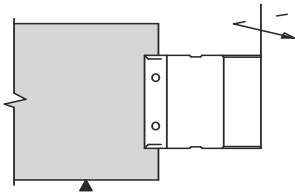

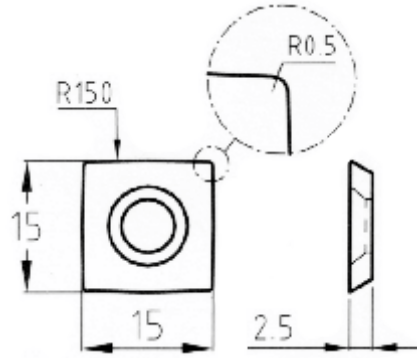
2176**HM: SPIRAL JİLETLİ PLANYA TOPU**

* Radüslü jiletler sayesinde, helisel kesimlerde mükemmel temiz yüzeyler sağlar

"ERGAL" HAFİF ALAŞIMLI GÖVDE

KOD.	D	B	dmax	Z	Jilet Adedi	RPM Max.	Jilet Bıçak
2176 080 041	80	80	30	4	14	16.000	8120 150 002
2176 080 042	80	100	30	4	18	16.000	8120 150 002
2176 100 041	100	100	35	4	18	13.000	8120 150 002
2176 100 042	100	130	35	4	24	13.000	8120 150 002
2176 125 041	125	100	50	4	18	10.000	8120 150 002
2176 125 042	125	130	50	4	24	10.000	8120 150 002
2176 125 061	125	100	50	6	27	10.000	8120 150 002
2176 125 062	125	130	50	6	36	10.000	8120 150 002
2176 125 064	125	230	50	6	66	10.000	8120 150 002
2176 140 081	140	100	50	8	36	9.000	8120 150 002
2176 140 082	140	130	50	8	48	9.000	8120 150 002

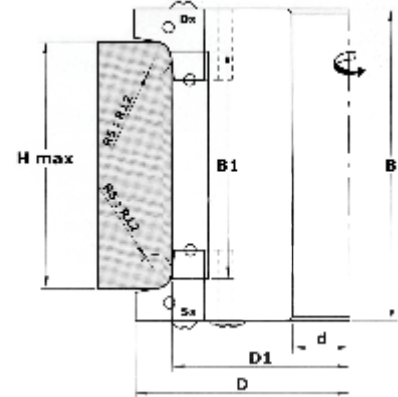
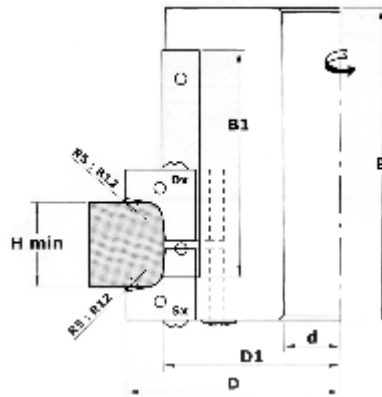
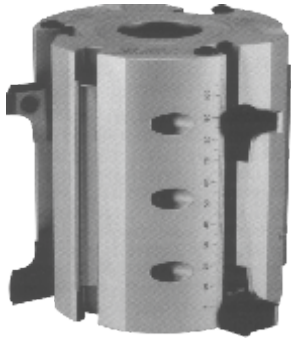
2203 - 2204**HM: AYARLANABİLİR RADÜSLÜ PLANYA TOPU**

"ERGAL" HAFİF ALAŞIMLI GÖVDE

2203 Z= 2+4

KOD.	D	D1	B	B1	dmax	H min/max	R
2203 125 080	151	125	110	80	50	30/87	5-12
2203 125 100	151	125	130	100	50	30/107	5-12
2203 125 120	151	125	150	120	50	30/127	5-12

2204 Z= 3+6

KOD.	D	D1	B	B1	dmax	H min/max	R
2204 125 080	151	125	110	80	50	30/87	5-12
2204 125 100	151	125	130	100	50	30/107	5-12
2204 125 120	151	125	150	120	50	30/127	5-12

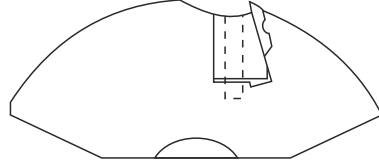
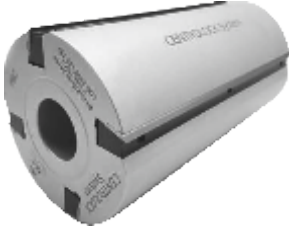

* Centrolock Sistem
ergal hafif alaşım gövdeli
planya topu

KOD.	D	B	dmax	Z	RPM Max.
2198 100 080	100	80	35	4	13000
2198 100 100	100	100	35	4	13000
2198 100 130	100	130	35	4	13000
2198 125 080	125	80	40	4	10000
2198 125 100	125	100	40	4	10000
2198 125 130	125	130	40	4	10000
2198 125 150	125	150	40	4	10000
2198 125 160	125	160	40	4	10000
2198 125 210	125	210	40	4	10000
2198 125 230	125	230	40	4	10000
2198 125 240	125	240	40	4	10000
2198 140 080	140	80	40	6	9000
2198 140 100	140	100	40	6	9000
2198 140 130	140	130	40	6	9000
2198 140 150	140	150	40	6	9000
2198 140 160	140	160	40	6	9000
2198 140 210	140	210	40	6	9000
2198 140 230	140	230	40	6	9000
2198 140 240	140	240	40	6	9000

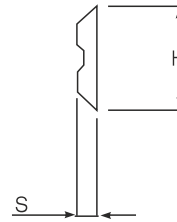
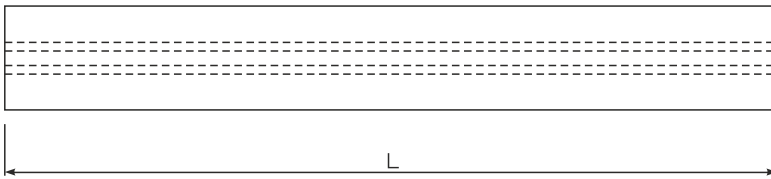

* Centrolock HM ve HSS
yedek jilet bıçaklar

KOD. HM	L	H	S
8016 080 000	080	16	3
8016 100 000	100	16	3
8016 130 000	130	16	3
8016 150 000	150	16	3
8016 160 000	160	16	3
8016 210 000	210	16	3
8016 230 000	230	16	3
8016 240 000	240	16	3

KOD. HSS	L	H	S
8017 080 000	080	16	3
8017 100 000	100	16	3
8017 130 000	130	16	3
8017 150 000	150	16	3
8017 160 000	160	16	3
8017 210 000	210	16	3
8017 230 000	230	16	3
8017 240 000	240	16	3

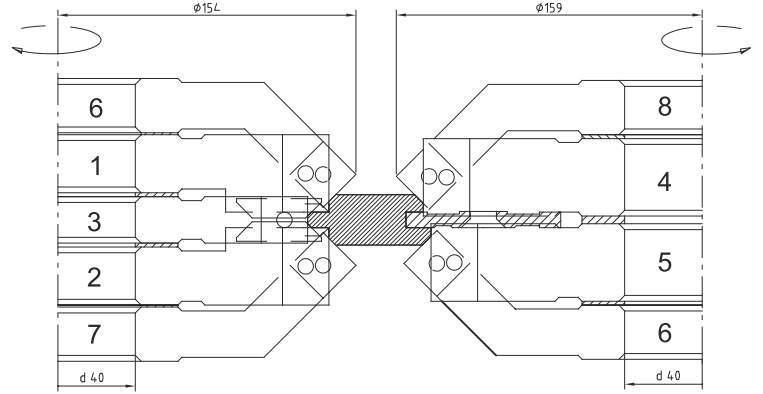
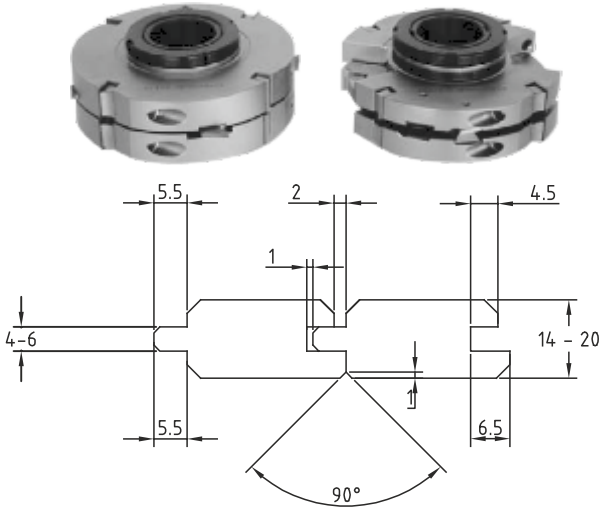
2325**HM: JİLET BIÇAKLI DÖŞEME PARKE FREZELERİ**

KOD.	D	B	d	Z	Freze No.	Freze Adedi	RPM Max.
232500001	140	20	40	4+2+2	1	1	8.000
232500002	140	20	40	4+2+2	2	1	8.000
232500003	127	12	40	2	3	1	8.000
232500004	144	20	40	4+2	4	1	8.000
232500005	140	20	40	4+2	5	1	8.000
232500011	154	12	40	2	6	2	8.000
232500012	154	12	40	2	7	1	8.000
232500013	159	12	40	2	8	1	8.000

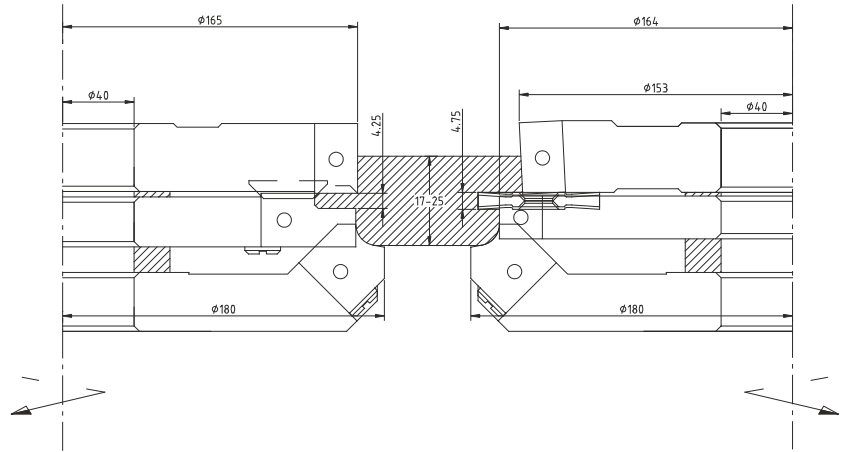
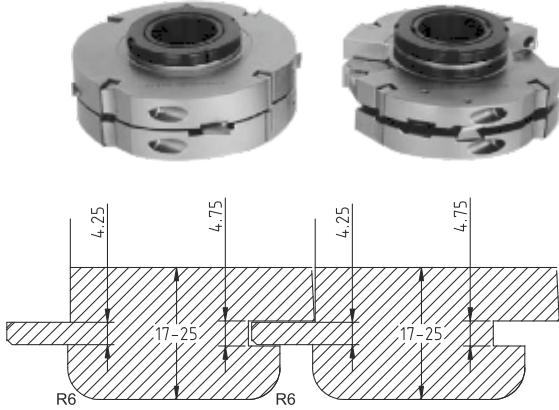
3092**HM: JİLET BIÇAKLI LAMBRI FREZE SETİ****3092 Z=4**

KOD.	D	H	d	Z	Freze Yön	RPM Max.
3092 000 001	180	17-25	40	4+2	Sağ	8.000
3092 000 002	180	17-25	40	4+2+2	Sol	8.000

3092 Z=2

KOD.	D	H	d	Z	Freze Yön	RPM Max.
3092 000 001	180	17-25	40	2+2	Sağ	8.000
3092 000 002	180	17-25	40	2+2+2	Sol	8.000

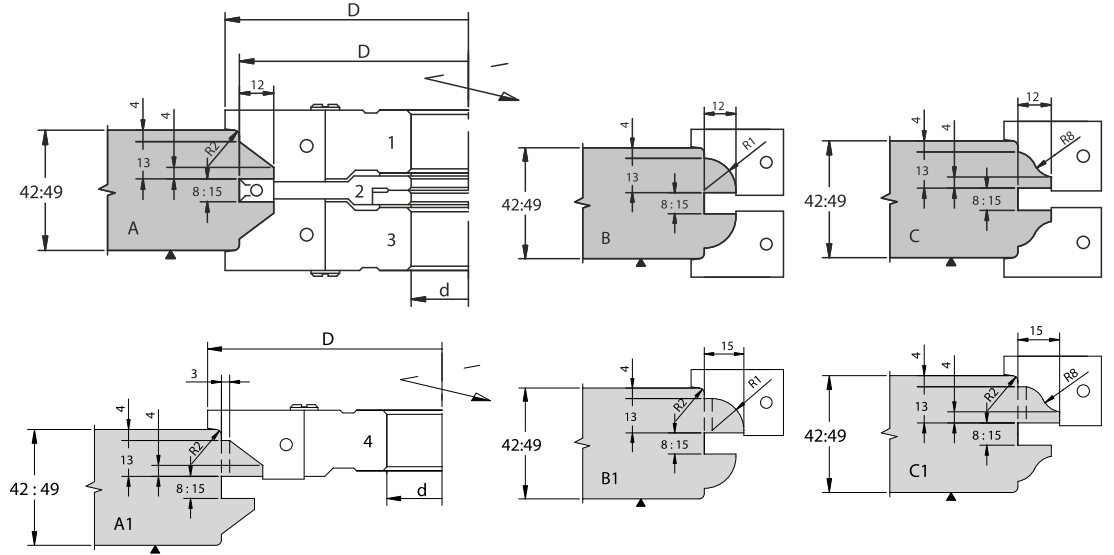

KOD.	D	B	d	No.	Gövde	RPM Max.	Z	Jilet Bıçak
3005 000 001	170	25	50	1	Ergal Alaşım	4.800 - 8.500	2	8170 025 035
3005 000 002	160	8/15	50	2	Ergal Alaşım	4.800 - 8.500	2	8105 076 012
3005 000 003	170	25	50	3	Ergal Alaşım	4.800 - 8.500	2	8170 025 035
3005 000 004	170	25	50	4	Ergal Alaşım	4.800 - 8.500	2	8170 025 035

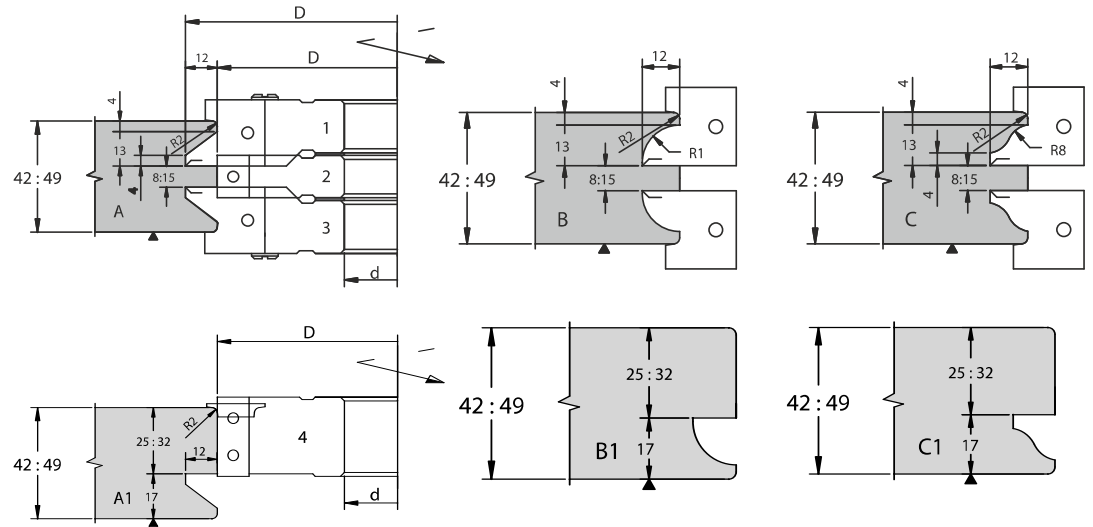

KOD.	D	B	d	No.	Gövde	RPM Max.	Z	Jilet Bıçak
3010 000 001	160	25	50	1	Ergal Alaşım	4.800 - 8.500	2	8170 025 030
3010 000 002	136	15	50	2	Ergal Alaşım	4.800 - 8.500	2	8105 150 012
3010 000 003	160	25	50	3	Ergal Alaşım	4.800 - 8.500	2	8170 025 030
3010 000 004	136	40	50	4	Ergal Alaşım	4.800 - 8.500	2	8105 400 012

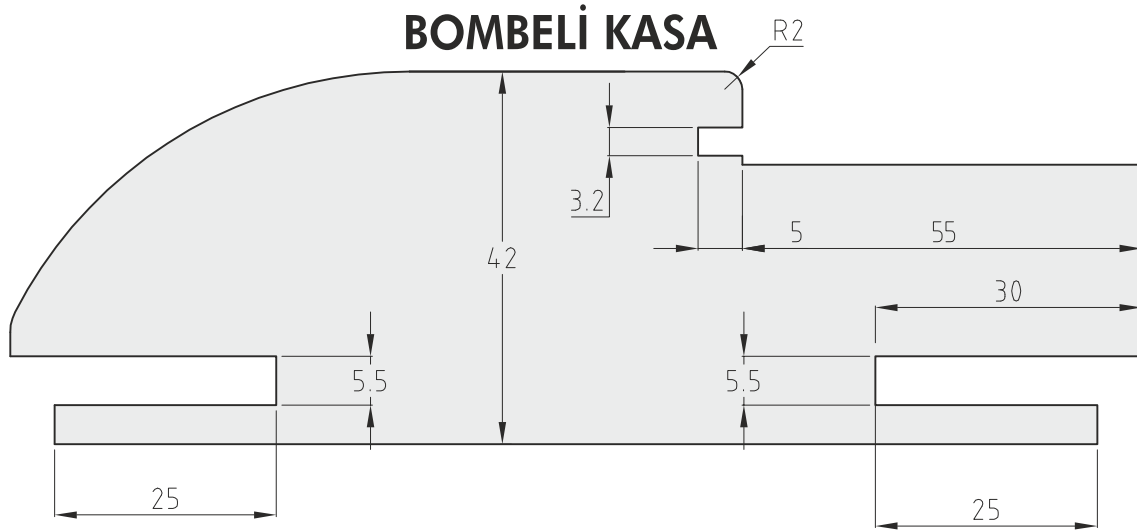
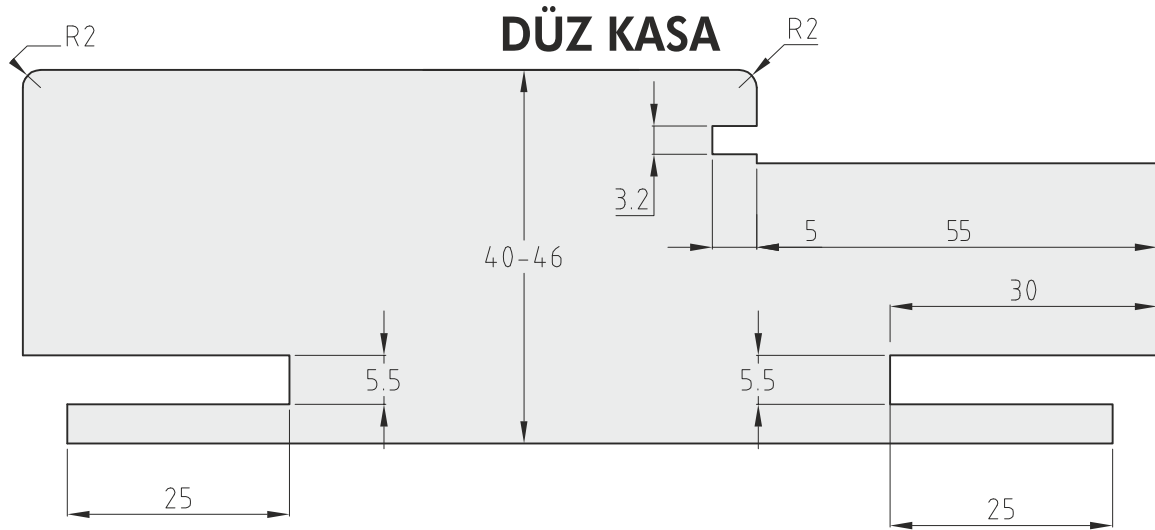

PERVAZLAR

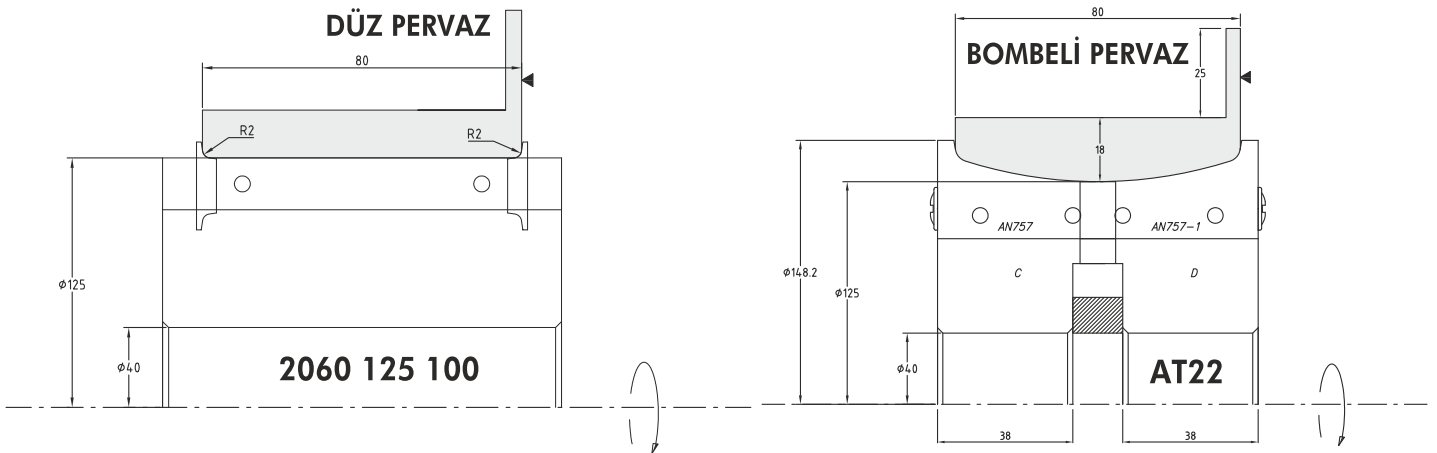

KOD.	MİL	D	S	d	Z	RPM Max.
2060 125 100 (DÜZ PERVAZ)	2.ALT	125	100	40	4	7.000
AT22 (BOMBELİ PERVAZ)	2.ALT	142,2	125	40	3+3	7.000

5 MİLLİ MAKİNA İÇİN JİLET BIÇAKLI KASA FREZE SETİ

KOD.	MİL	TAKIM	D	S	d	Z	RPM Max.
2090 135 050	1.ALT	P	135	50	40	4+4	7.000
2055 110 012	1.SAĞ	I	110	12	50	2	7.000
9140 160 4555	1.SAĞ	L	160	4,5	50	12	7.000
2030 100 015	1.SAĞ	N	100	15/30	50	2+2	7.000
9140 210 3250	1.SAĞ	M	210	3,2	50	24	7.000
8385 540 095 (FLANŞ)	1.SAĞ		50	95	40		7.000
2055 110 012	1.SOL	E	110	12	50	2	7.000
9140 160 4540	1.SOL	F	160	4,5	50	12	7.000
2055 100 040	1.SOL	G	100	40	50	2+2	7.000
2350 200 060 (BOMBELİ KASA)	1.SOL	H	202	60	50	2	7.000
8385 540 095 (FLANŞ)	1.SOL		50	95	40		7.000
AT10	2.ALT	O	135	60	40	2+2+2+2	7.000

6 MİLLİ MAKİNA İÇİN JİLET BIÇAKLI KASA FREZE SETİ

KOD.	MİL	TAKIM	D	S	d	Z	RPM Max.
2055 110 050	1.SAĞ	A	110	50	50	2	7.000
2085 170 012	1.SAĞ	B	170	12	50	2+2	7.000
8385 540 095 (FLANŞ)	1.SAĞ		50	95	40		7.000
2055 110 012	1.SOL	E	110	12	50	2	7.000
9140 160 4540	1.SOL	F	160	4,5	50	12	7.000
2055 100 040	1.SOL	G	100	40	50	2+2	7.000
2350 200 060 (BOMBELİ KASA)	1.SOL	H	202	60	50	2	7.000
8385 540 095 (FLANŞ)	1.SOL		50	95	40		7.000
2055 110 012	2.SAĞ	I	120	12	50	2	7.000
9140 160 4550	2.SAĞ	L	170	4,5	50	12	7.000
2030 100 015	1.SAĞ	N	100	15/30	50	2+2	7.000
9140 210 3250	2.SAĞ	M	210	3,2	50	24	7.000
8385 540 095 (FLANŞ)	2.SAĞ		50	95	40		7.000
At10	2.ALT	O	135	60	40	2+2+2+2	7.000

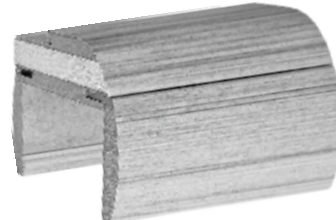
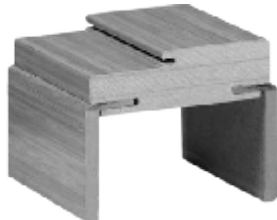

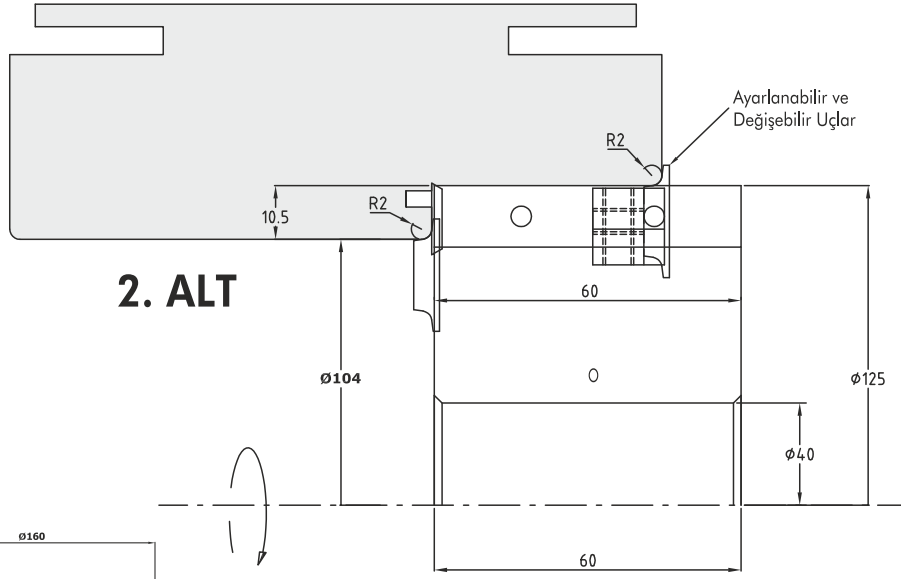

AT10

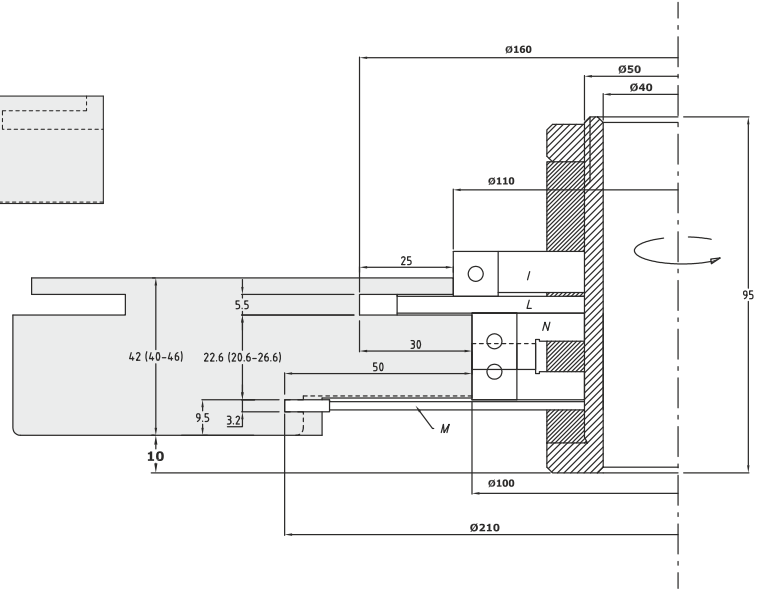
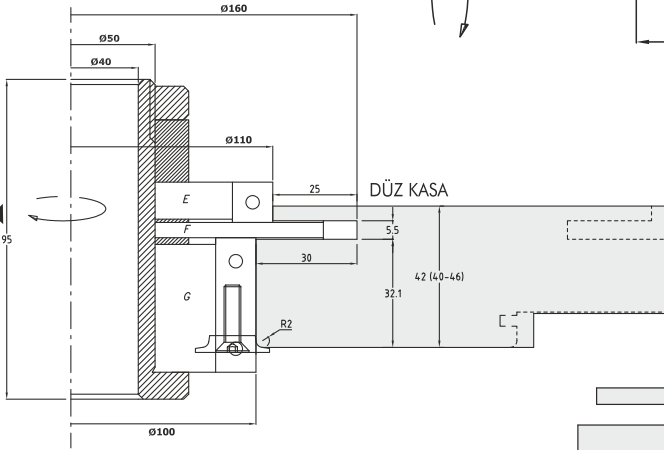

1. SAĞ

1. SOL

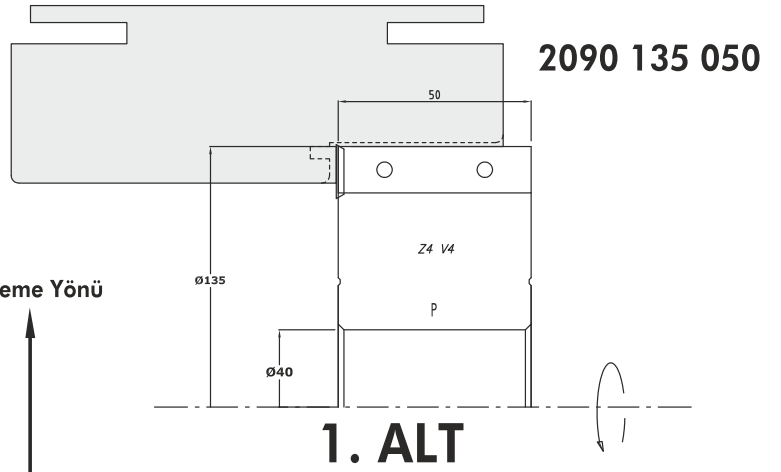
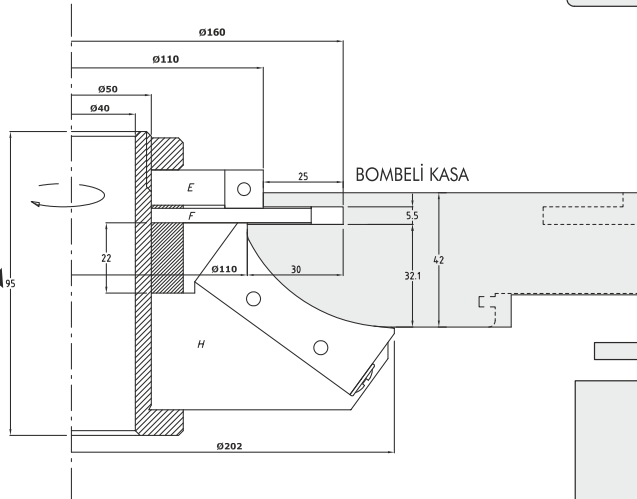

1. ALT

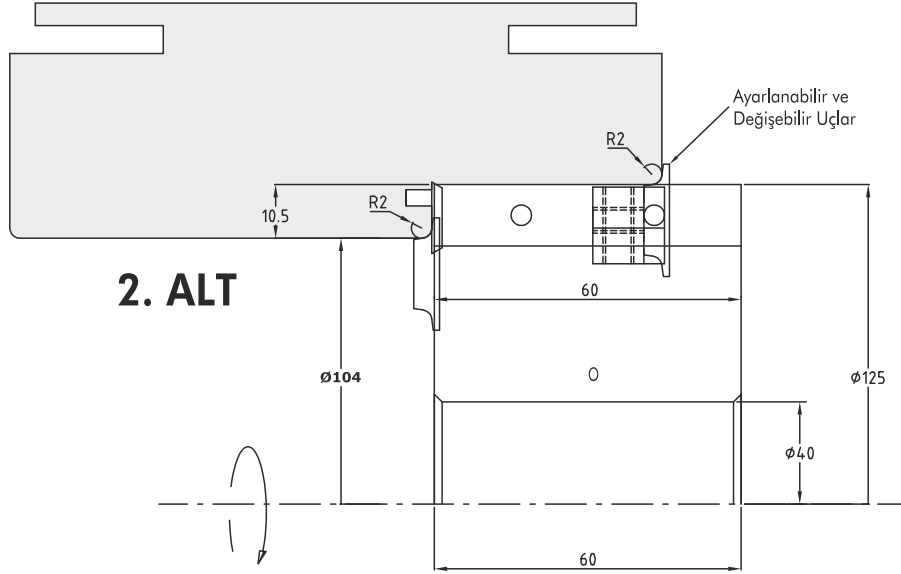

2. ALT

AT10

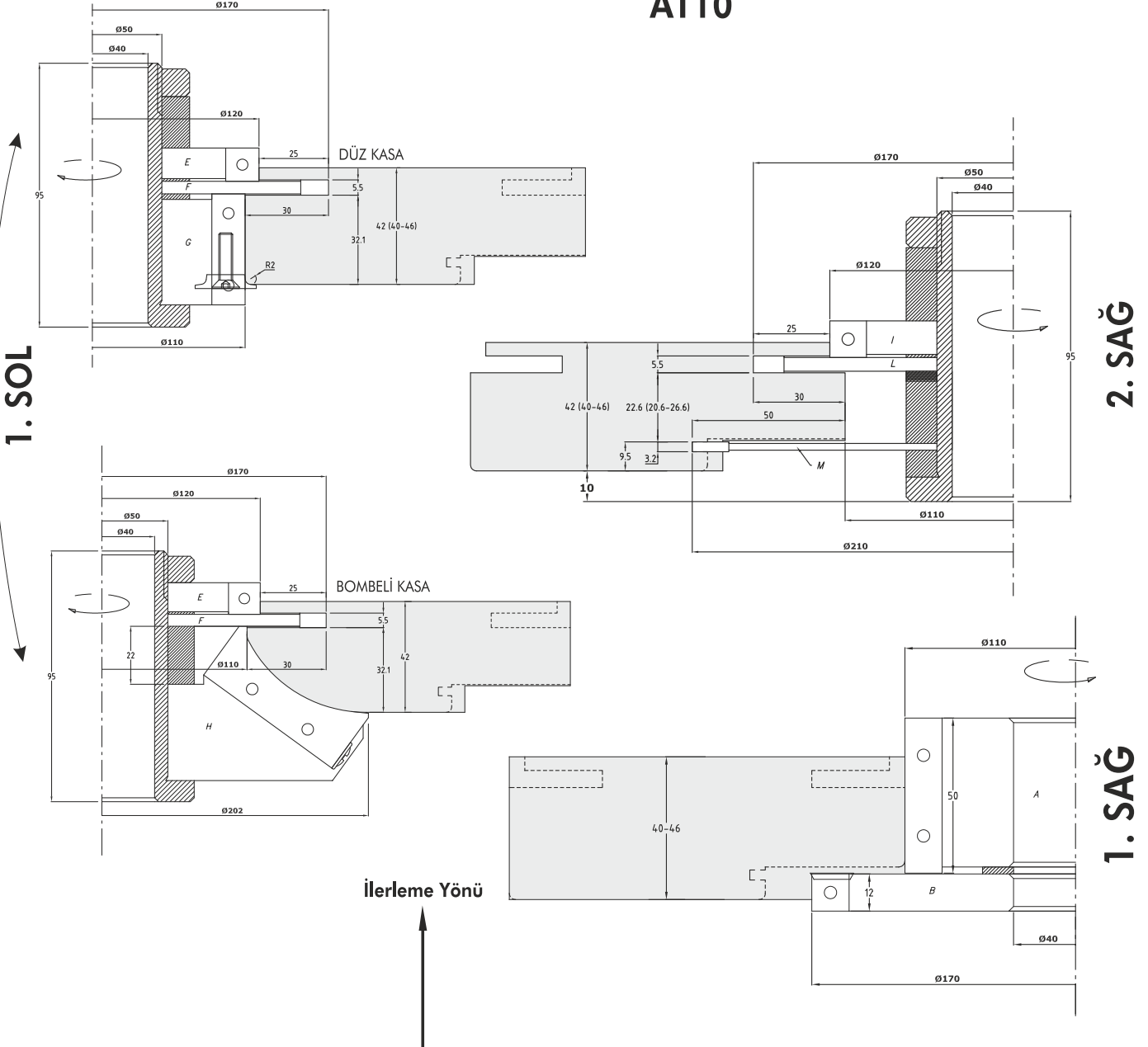

1. SOL

2. SAĞ

1. SAĞ

İlerleme Yönü

- * Ahşap Pencere ve Kapı Frezeleri
- * Sürgülü Kapı ve Pencere Frezeleri
- * Ahşap Pivot Pencere Frezeleri

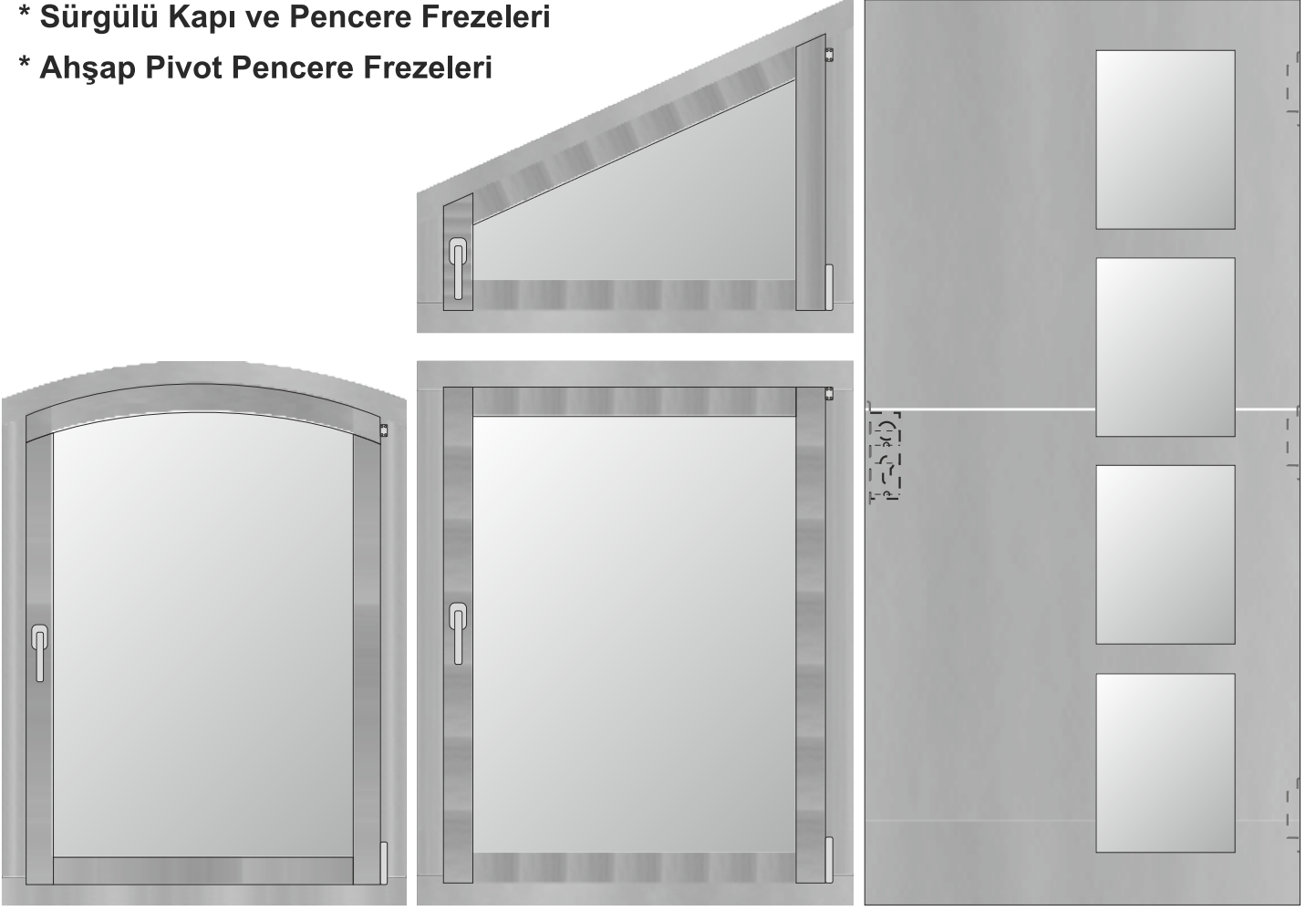

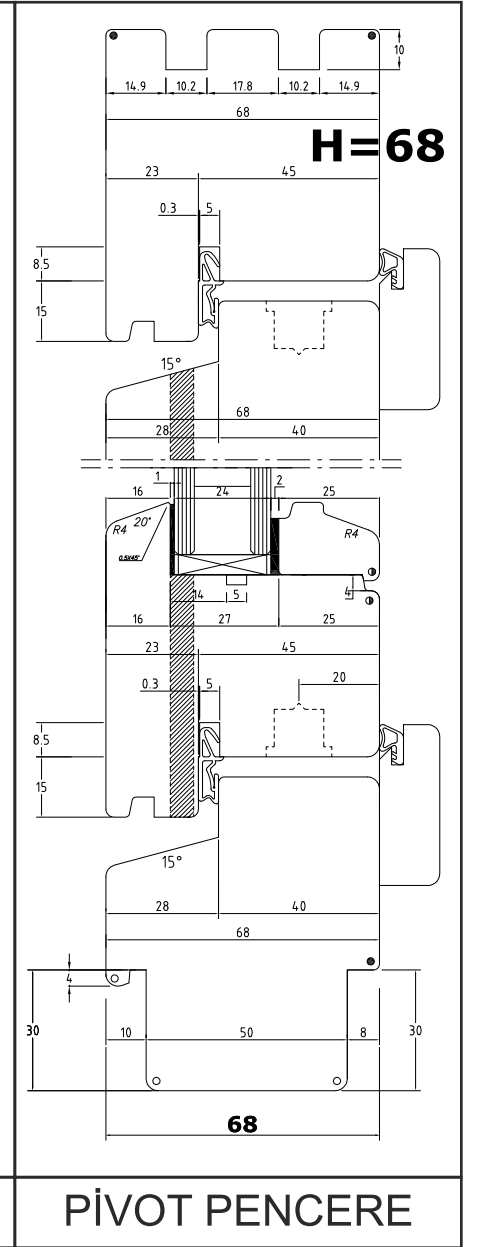
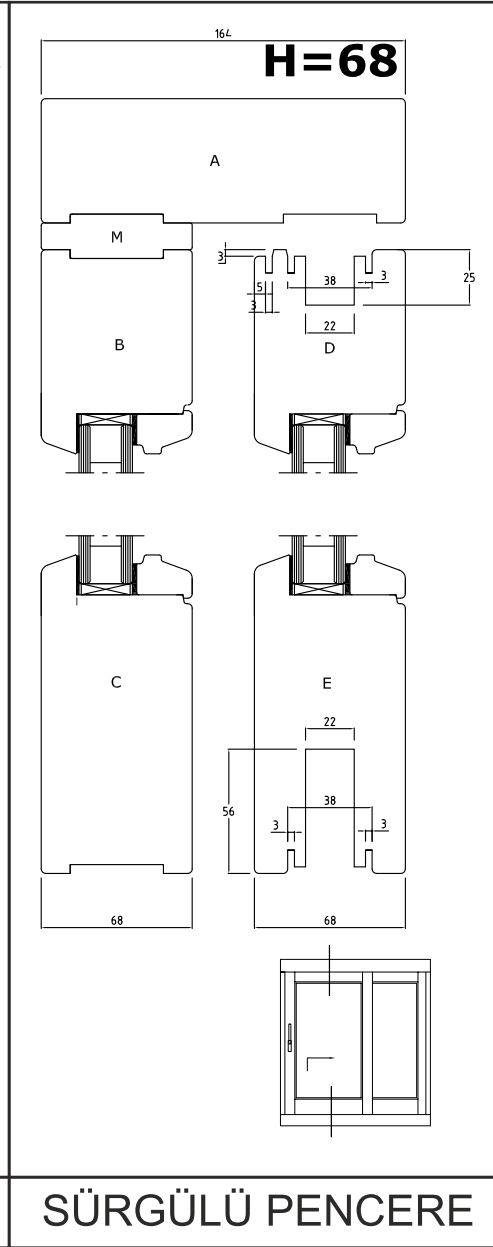
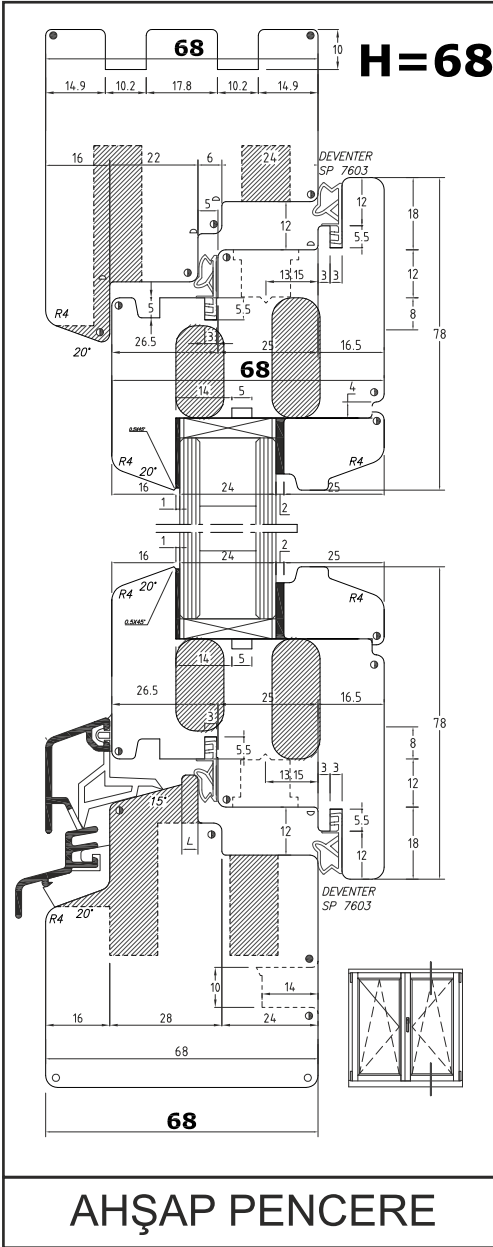
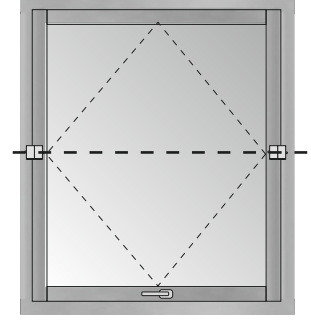
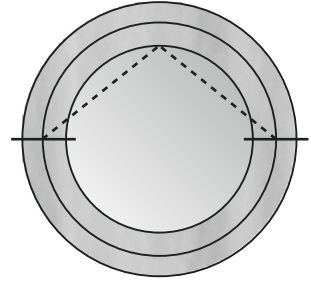
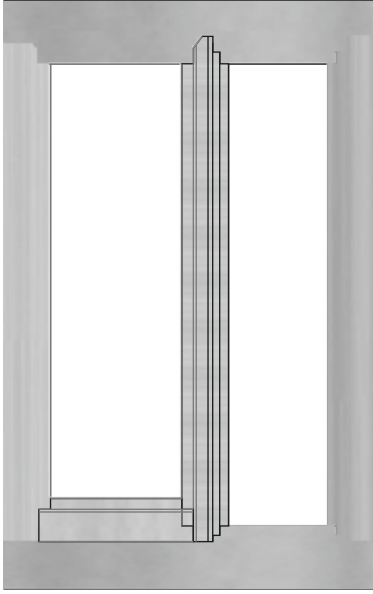

Diamond Frezeler





BUP[®]
U T E N S I L I

www.buputensili.it

6032

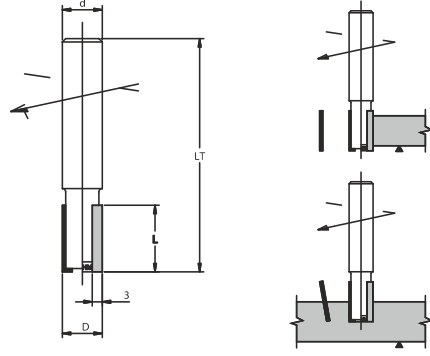
DP: DIAMOND KANAL VE EBATLAMA FREZELERİ



- * Kaplamalı Yada Kaplamasız Sunta ve Mdf Panellerin Ebatlanması, Kanal Açılması
- * Ekonomik Tip
- * 2-3 kez Bilenebilir.
- * Z 2



KOD.	D	L	d	LT.	S	RPM Max.	Z
6032 060 010	6	10	8	70	3	24.000	1
6032 080 015	8	15	10	70	3	24.000	2
6032 090 015	9	15	10	70	3	24.000	2
6032 100 020	10	20	12	70	3	24.000	2
6032 120 025	12	25	12	80	3	24.000	2

6037

DP: DIAMOND EBATLAMA FREZELERİ

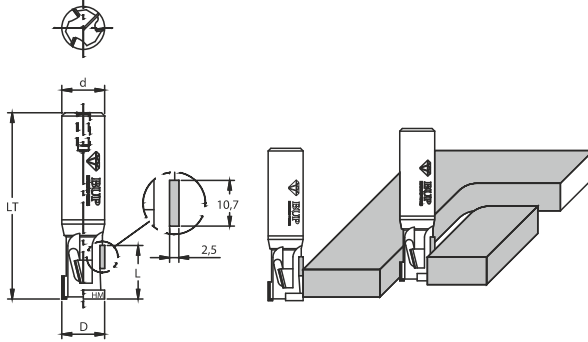

- * Kaplamalı Yada Kaplamasız Sunta ve Mdf Panellerin Ebatlanması, Kanal Açılması
- * Ekonomik Tip
- * 2-3 kez Bilenebilir.
- * Z 1



KOD.	D	L	d	LT.	S	RPM Max.	Z
6037 012 025	12	25	20	85	2,5	20.000	3+1
6037 016 036	16	34	20	95	2,5	20.000	4+1
6037 018 045	18	43	20	105	2,5	20.000	5+1
6037 018 052	18	52	18	115	2,5	20.000	6+1

6050

DP: DIAMOND EBATLAMA FREZELERİ

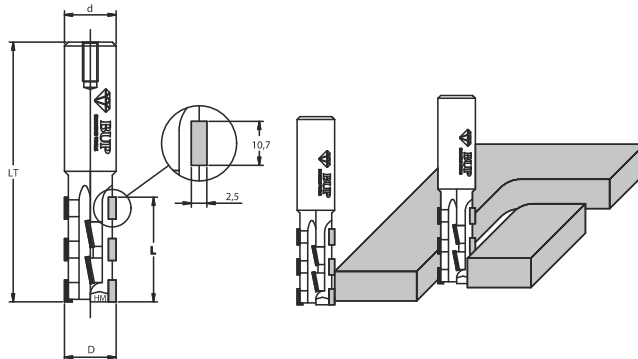

- * Sunta-lam ve Mdf-lam Panellerin Ebatlanması, Kanal Açılması
- * Ekonomik Tip
- * 2-3 kez Bilenebilir.
- * Z 2



KOD.	D	L	d	LT.	S	RPM Max.	Z
6050 012 021	12	21	12	75	2,5	20.000	4+1
6050 018 025	18	25	20	85	2,5	20.000	6+1
6050 018 034	18	34	20	95	2,5	20.000	8+1
6050 018 043	18	43	20	105	2,5	20.000	10+1
6050 020 052	20	52	20	115	2,5	20.000	12+1

6030

DP: DIAMOND CNC RADIUS FREZELERİ

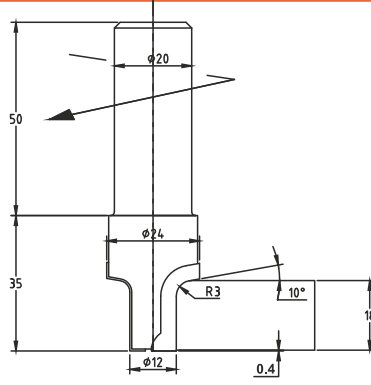

- * Düz Tabla Yada Vakum Fincanlı CNC Makinalarda Ebatlama ve Kapak Kenar Radius Frezeleri
- * R1 - R2 - R3 - R4 - R5 - R6
- * 8 - 10 kez Bilenebilir.



KOD.	D	L	R	d	S	RPM Max.	Z
6030 023 035	24	85	1	20	4	24.000	2+1
6030 024 035	24	85	2	20	4	24.000	2+1
6030 025 035	24	85	3	20	4	24.000	2+1
6030 026 035	26	85	4	20	4	24.000	2+1
6030 028 035	28	85	5	20	4	24.000	2+1
6029 022 035	22	85	3	20	4	24.000	3

6140

DP: DIAMOND CNC EBATLAMA FREZELERİ

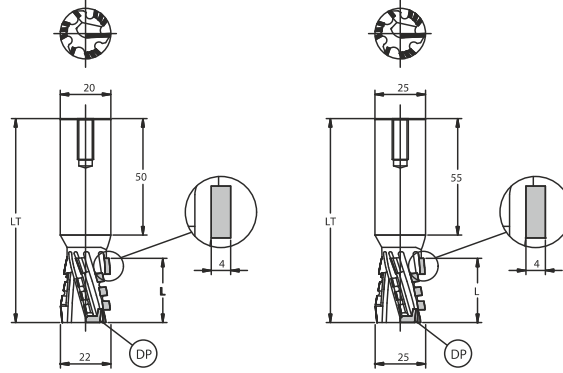

- * Sunta-lam ve Mdf-lam Panellerin Ebatlanması
- * Z 3
- * 8 - 10 kez Bilenebilir.



KOD.	D	L	d	S	LT.	RPM Max.	Z
6140 022 025	22	25	20-25	4	85	24.000	3
6140 025 030	25	30	20-25	4	95	24.000	3
6140 025 050	25	50	20-25	4	115	24.000	3

6141

DP: DIAMOND CNC EBATLAMA FREZESİ

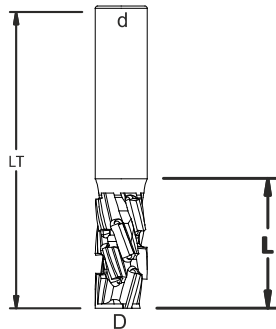

- * Sunta-lam ve Mdf-lam Panellerin Ebatlanması
- * Z 3+3
- * Sertleştirilmiş ağır çelik gövde.
- * H 3mm elmas yüksekliği

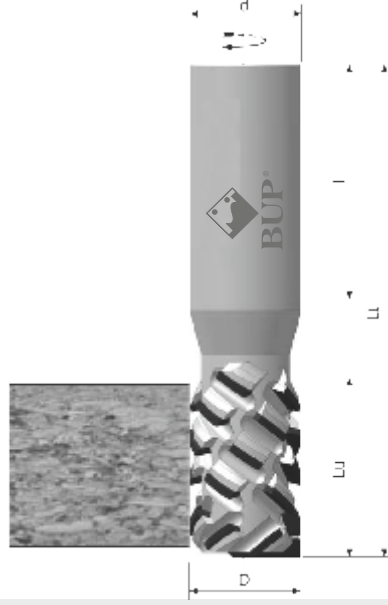

KOD.	D	L	d	S	LT	RPM Max.	Z
6141 120 025	12	25	12	3	70	20.000	3+3
6141 160 035	16	35	16	3	95	20.000	3+3
6141 180 043	18	43	18	3	105	20.000	3+3

6144**DP: DIAMOND CNC 54° HELİSEL FREZESİ**

- * 54° yüksek kesim açısı sayesinde sunta ve mdf panellerin ebatlanmasında uzun ömür ve temiz yüzey
- * H 4 mm yüksekliğinde Diamond uçlar sayesinde 8 kez bilenmeyi garanti eder.
- * Z2+2+2 H4 54°

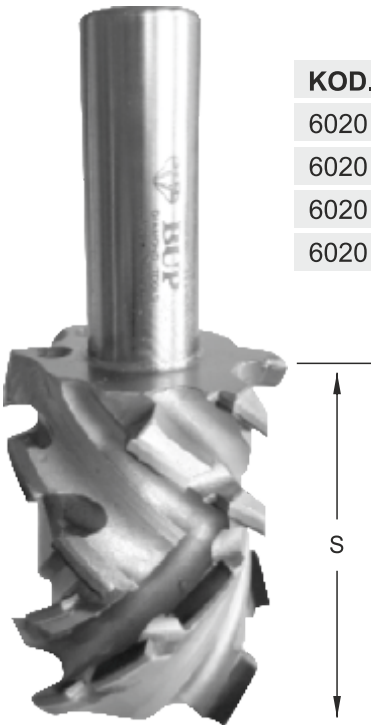

KOD.	D	Lu	Lt	ŞAFT		Z	DÖNÜŞ YOLU	UÇ SAYISI	
				d mm	l mm			n°	Dalış
6144 025 030	25	30	95	20 / 25	55	2	SAĞ	18	1 DP
6144 025 031	25	30	95	20 / 25	55	2	SOL	18	1 DP
6144 025 040	25	40	105	20 / 25	55	2	SAĞ	24	1 DP
6144 025 041	25	40	105	20 / 25	55	2	SOL	24	1 DP
6144 025 495	25	49,5	115	20 / 25	55	2	SAĞ	30	1 DP
6144 025 496	25	49,5	115	20 / 25	55	2	SOL	30	1 DP
6144 025 059	25	59	125	20 / 25	55	2	SAĞ	36	1 DP
6144 025 060	25	59	125	20 / 25	55	2	SOL	36	1 DP

6020-6021**DP: DIAMOND CNC 54° KENAR TEMİZLEME**

KOD. RH	KOD. LH	D	S	L	Z	Uç
6020 050 022	6021 050 022	50	22	85	4+2+4	12
6020 050 030	6021 050 030	50	30	90	4+2+4	16
6020 050 039	6021 050 039	50	39	100	4+2+4	20
6020 050 048	6021 050 048	50	48	110	4+2+4	24

- * 54° yüksek kesim açısı sayesinde sunta ve mdf panellerin kenar temizlemede uzun ömür ve temiz yüzey
- * H 4 mm yüksekliğinde Diamond uçlar sayesinde 8 kez bilenmeyi garanti eder.
- * Z4+2+4 H4 54°



6030**DP: DIAMOND CNC CAM YERİ FREZESİ**

15063602A

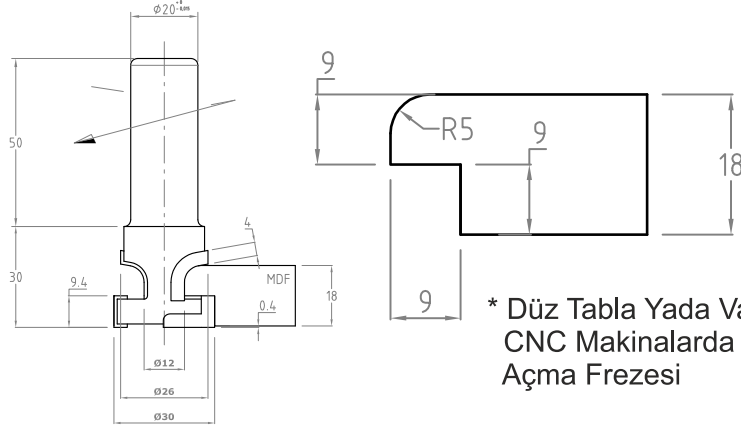

* Düz Tabla Yada Vakum Fincanlı
CNC Makinalarda Cam Yeri
Açma Frezesi



KOD.	D	L	R	d	S	RPM Max.	Z
6030 030 030	30	80	5	20	4	24.000	2+2

6030**DP: DIAMOND CNC KAPAK FREZELERİ**

15006501A

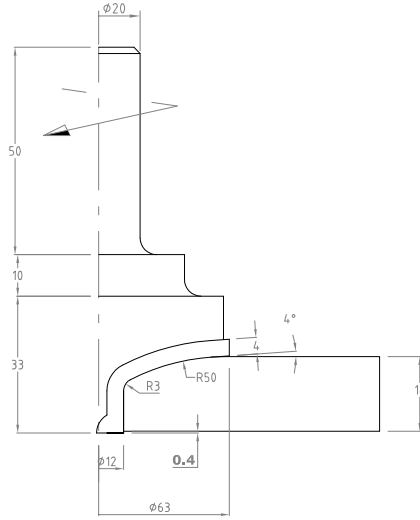

* Düz Tabla Yada Vakum Fincanlı
CNC Makinalarda Profil
Açma Frezesi



KOD.	D	L	R	d	S	RPM Max.	Z
6030 065 030	63	93	50	20	4	16.000	2

6030**DP: DIAMOND CNC KAPAK FREZELERİ**

15006501A

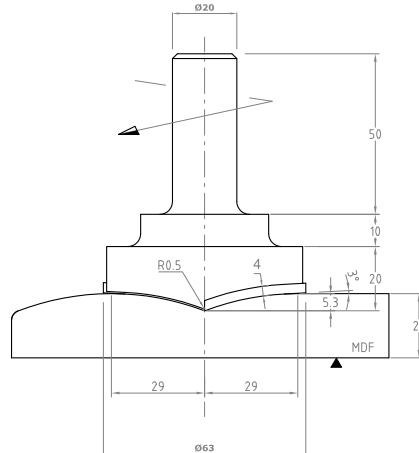

* Düz Tabla Yada Vakum Fincanlı
CNC Makinalarda Profil
Açma Frezesi

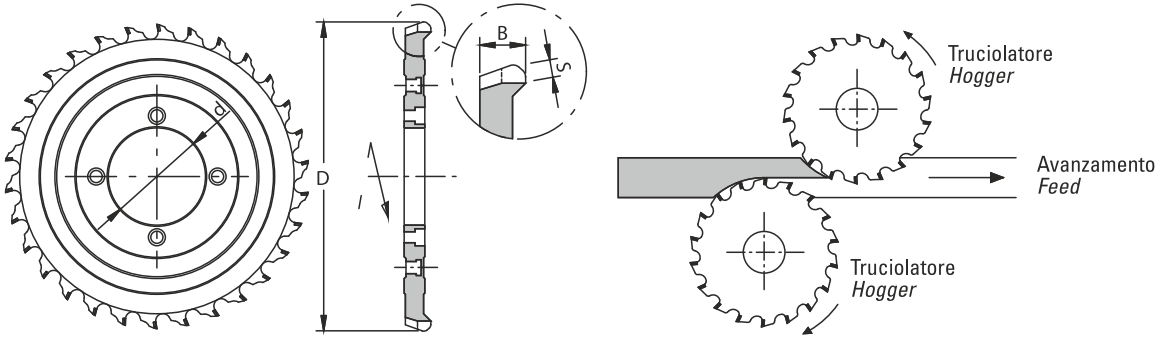

KOD.	D	L	R	d	S	RPM Max.	Z
6030 065 030	63	93	81	20	4	18.000	2

6200-6201**DP: DIAMOND COMPACT RADIUS PARÇALAYICILAR**

* Çift Kenar İşlem Makinaları Parçalayıcıları
* IMA, Homag, Biesse

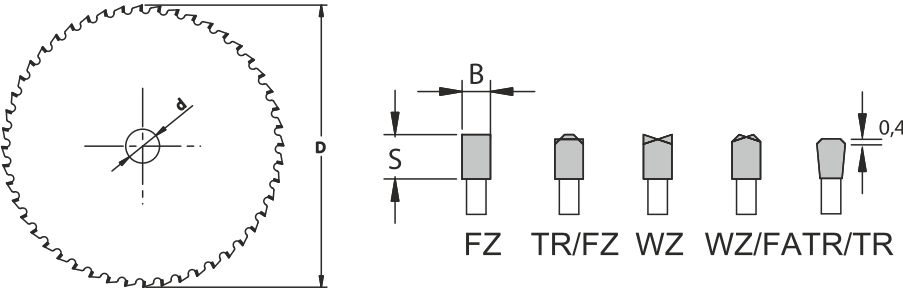

KOD. RH - LH	D	B	Dönüş	S	RPM Max.	Z
6200/6201 250 001	250	20	Sağ - Sol	6	7.000	30+6+6 (36)
6200/6201 250 002	250	20	Sağ - Sol	6	7.000	36+6+6 (42)

6250**DP: DIAMOND KESİCİ TESTERELER**

* Panel Ebatlama Makinaları Diamond Kesici Testereleri
* 10 - 12 kez Bilenebilir.

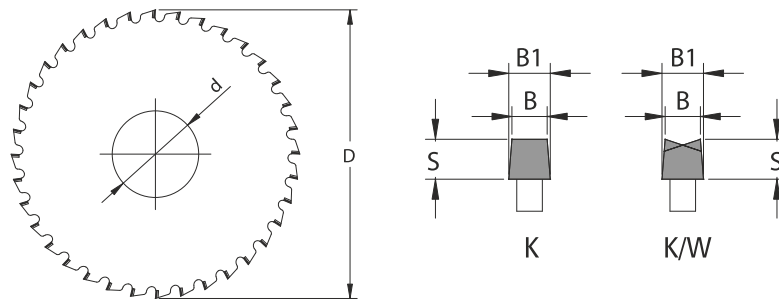

KOD.	D	B	d	S	RPM Max.	Z
6250 300 011	300	4.4	30-80	3	8.000	60
6250 300 012	300	4.4	30-80	6	8.000	60
6250 350 012	350	4.4	30-80	6	6.000	72
6250 400 012	400	4.4	30-80	6	5.500	72
6250 450 011	450	4.6	75-80	6	4.500	72

6260**DP: DIAMOND ÇİZİCİ TESTERELER**

* Panel Ebatlama Makinaları Diamond Çizici Testereleri
* 10 - 12 kez Bilenebilir.

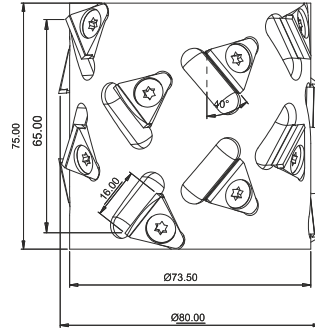
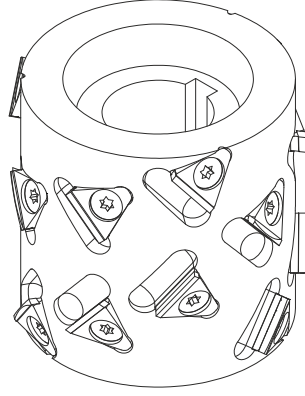

KOD.	D	B/B1	d	S	RPM Max.	Z
6260 150 002	150	4.3÷5.4	30-80	6	12.000	36
6260 160 002	160	4.3÷5.4	30-80	6	12.000	36
6260 180 002	180	4.3÷5.4	30-80	6	10.000	36
6260 200 002	200	4.3÷5.4	30-80	6	10.000	36
6260 300 002	300	4.3÷5.4	75-80	6	8.000	48

6387-6388**DP: DIAMOND KENAR TEMİZLEME FREZELERİ**

- * Alüminyum hafif gövdeli Değişebilir PCD uçlu Kenar bantlama frezeleri
- * S (simetrik) AS (asimetrik) 2 farklı model

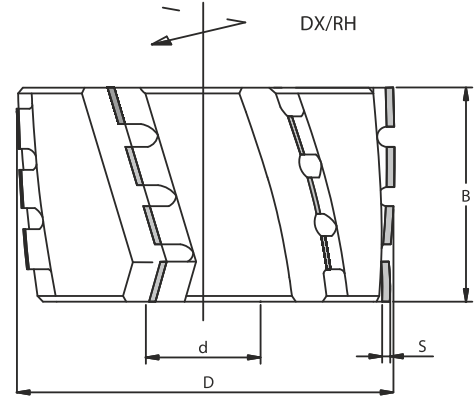
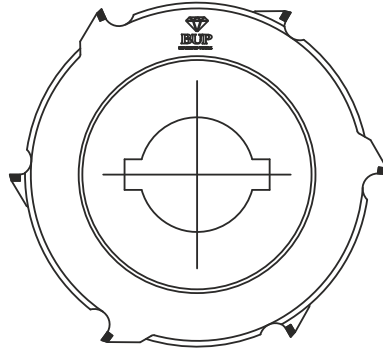

Makina	D mm	SB mm	Bo. mm	Dönüş	Z	Kod.
HolzHer	70	65	30 DKN	Sağ - Sol	3+3 / 18	6387-6388 070 065
HolzHer	100	45	30 DKN	Sağ - Sol	3+3 / 12	6387-6388 100 045
HolzHer	125	65	30 DKN	Sağ - Sol	3+3 / 18	6387-6388 125 065
Biesse	80	45	30 DKN	Sağ - Sol	3+3 / 12	6387-6388 080 045
Biesse	80	65	30 DKN	Sağ - Sol	3+3 / 18	6387-6388 080 065
Biesse	100	45	30 DKN	Sağ - Sol	3+3 / 12	6387-6388 100 045
Biesse	100	65	30 DKN	Sağ - Sol	3+3 / 18	6387-6388 100 065
Biesse	125	45	30 DKN	Sağ - Sol	3+3 / 12	6387-6388 125 045
Biesse	125	65	30 DKN	Sağ - Sol	3+3 / 18	6387-6388 125 065
Ott	85	45	30 DKN	Sağ - Sol	3+3 / 12	6387-6388 085 045
Ott	85	54	30 DKN	Sağ - Sol	3+3 / 15	6387-6388 085 054
Ott	85	65	30 DKN	Sağ - Sol	3+3 / 18	6387-6388 085 065
Ott	100	65	30 DKN	Sağ - Sol	3+3 / 18	6387-6388 100 065
Brandt	100	45	30 DKN	Sağ - Sol	3+3 / 12	6387-6388 100 045
Brandt	100	65	30 DKN	Sağ - Sol	3+3 / 18	6387-6388 100 065
Brandt	125	45	30 DKN	Sağ - Sol	3+3 / 12	6387-6388 125 045
IMA	125	45	30 DKN	Sağ - Sol	3+3 / 12	6387-6388 125 045
IMA	125	65	30 DKN	Sağ - Sol	3+3 / 18	6387-6388 125 065
Homag	100	45	30 DKN	Sağ - Sol	3+3 / 12	6387-6388 100 045
Homag	100	65	30 DKN	Sağ - Sol	3+3 / 18	6387-6388 100 065
Homag	125	45	30 DKN	Sağ - Sol	3+3 / 12	6387-6388 125 045
Homag	125	65	30 DKN	Sağ - Sol	3+3 / 18	6387-6388 125 065
Törk	80	65	30 DKN	Sağ - Sol	3+3 / 18	6387-6388 080 065

6287-6288**DP: DIAMOND KENAR TEMİZLEME FREZELERİ**

* Çelik gövdeli Sabit PCD uçlu Kenar bantlama frezeleri

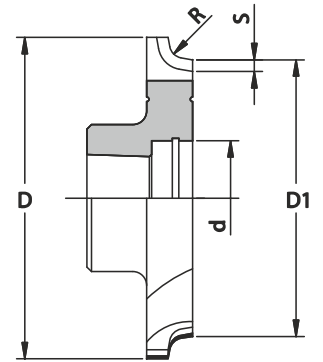
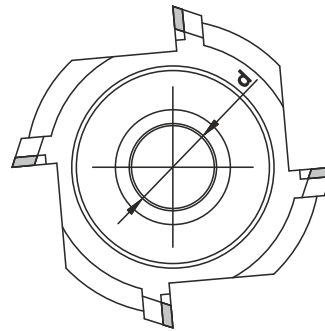

KOD. RH - LH	D	B	d	Dönüş	S	RPM Max.	Z
6287/6288 080 001	080	48	30 DKN	Sağ - Sol	2,5	18.000	3+3
6287/6288 080 002	080	63	30 DKN	Sağ - Sol	2,5	18.000	3+3
6287/6288 100 001	100	48	30 DKN	Sağ - Sol	2,5	15.000	3+3
6287/6288 100 002	100	63	30 DKN	Sağ - Sol	2,5	15.000	3+3
6287/6288 125 001	125	48	30 DKN	Sağ - Sol	2,5	15.000	3+3
6287/6288 125 002	125	63	30 DKN	Sağ - Sol	2,5	15.000	3+3
6287/6288 150 001	150	48	30 DKN	Sağ - Sol	2,5	15.000	3+3
6287/6288 150 002	150	63	30 DKN	Sağ - Sol	2,5	15.000	3+3

6300-6301**DP: DIAMOND KÖŞE YUVARLAMA FREZELERİ**

* Kenar Bantlama Makinaları Radius Frezeleri

* IMA, Biesse, Homag, Holz-Her v.b.



KOD. RH - LH	D	D1	d	R	Dönüş	S	RPM Max.	Z
6300/6301 062 020	70	62	HSK25R	2	Sağ - Sol	2,5	24.000	4
6300/6301 062 030	72	62	HSK25R	3	Sağ - Sol	2,5	24.000	4
6300/6301 070 020	78	70	HSK25R	2	Sağ - Sol	2,5	24.000	4
6300/6301 070 030	80	70	HSK25R	3	Sağ - Sol	2,5	24.000	4

6487 - 6488**DP: DIAMOND 45° KENAR TEMİZLEME****KENAR BANTLAMA FREZESİ PCD Z.3+3 DP H5 - 45°**

- * Çelik gövdeli Sabit PCD uçlu Kenar bantlama frezeleri
- * 45° kesim açısı
- * H 5mm uç yüksekliği

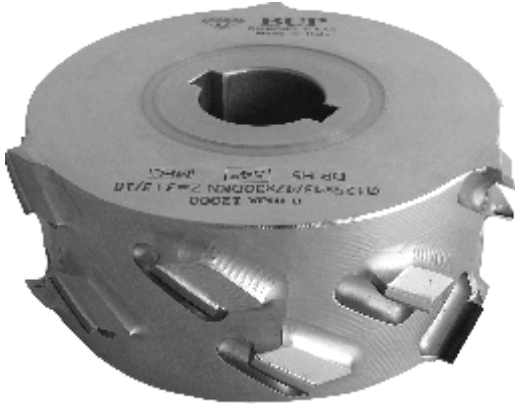

KOD. RH	KOD. LH	D	l	d	Z	Uç
6487 100 048	6488 100 048	100	48	30DKN	3+3	30
6487 100 063	6488 100 063	100	63	30DKN	3+3	39
6487 125 048	6488 125 048	125	48	30DKN	3+3	30
6487 125 063	6488 125 063	125	63	30DKN	3+3	39

6587 - 6588**DP: DIAMOND 54° KENAR TEMİZLEME****KENAR BANTLAMA FREZESİ PCD Z.3+3 DP H5 - 54°**

- * Çelik gövdeli Sabit PCD uçlu Kenar bantlama frezeleri
- * 54° kesim açısı
- * H 5mm uç yüksekliği



KOD. RH	KOD. LH	D	l	d	Z	Uç
6587 100 036	6588 100 036	100	36	30DKN	3+3	15
6587 100 043	6588 100 043	100	43	30DKN	3+3	18
6587 100 054	6588 100 054	100	54	30DKN	3+3	21
6587 100 061	6588 100 061	100	61	30DKN	3+3	24
6587 100 068	6588 100 068	100	68	30DKN	3+3	27
6587 125 036	6588 125 036	125	36	30DKN	3+3	15
6587 125 043	6588 125 043	125	43	30DKN	3+3	17
6587 125 054	6588 125 054	125	54	30DKN	3+3	21
6587 125 061	6588 125 061	125	61	30DKN	3+3	24
6587 125 068	6588 125 068	125	68	30DKN	3+3	27

Jiletler - Yedek Parçalar



BUP[®]
UTENSILI



www.buputensili.it

08

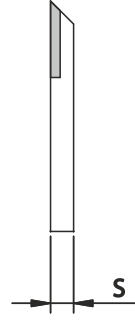
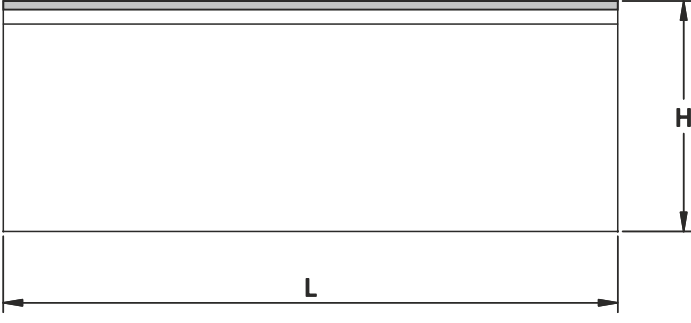
8005**HM: PLANYA BIÇAKLARI**

* HM planya bıçakları sert ağaçlarda yüksek performans sağlar.

KOD. HM-HSS	L	H	S
8005 100 030	100	30	3
8005 120 030	120	30	3
8005 130 030	130	30	3
8005 150 030	150	30	3
8005 160 030	160	30	3
8005 180 030	180	30	3
8005 230 030	230	30	3
8005 240 030	240	30	3
8005 300 030	300	30	3
8005 400 030	400	30	3
8005 500 030	500	30	3
8005 600 030	600	30	3
8005 810 030	810	30	3

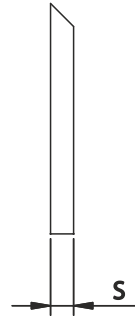
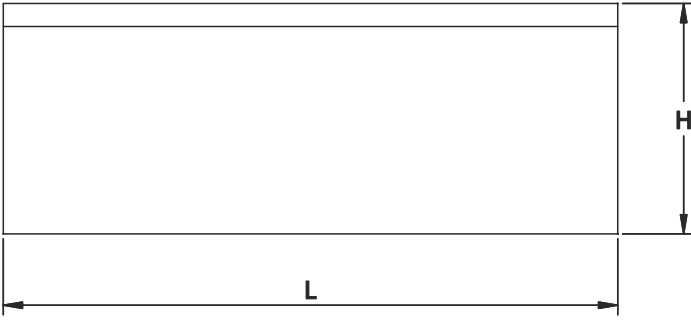
8010**HSS: PLANYA BIÇAKLARI**

* HSS bıçaklarda %18 Co karışım sayesinde aşırı ısınma engellenir, körelme süreleri gecikir, yüksek performans sağlar

KOD. HM-HSS	L	H	S
8010 100 030	100	30	3
8010 120 030	120	30	3
8010 130 030	130	30	3
8010 150 030	150	30	3
8010 160 030	160	30	3
8010 180 030	180	30	3
8010 230 030	230	30	3
8010 240 030	240	30	3
8010 300 030	300	30	3
8010 400 030	400	30	3
8010 500 030	500	30	3
8010 600 030	600	30	3
8010 810 030	810	30	3

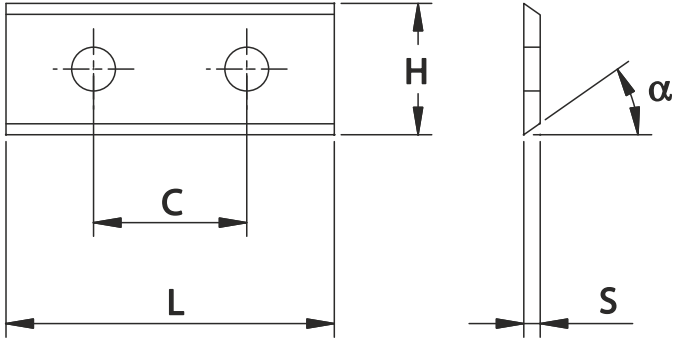
8102**HM: MİKRON GRADE SERT METAL JİLET BIÇAKLAR**

- * Sert Kalite
- * Sunta-lam ve Mdf-lam Paneller İçin
- * 2 Keskin Kenar

KOD.	L	H	S	C	Açı
8102 076 012	7,65	12	1,5	-	35°
8102 096 012	9,6	12	1,5	-	35°
8102 120 012	12	12	1,5	-	35°
8102 150 012	15	12	1,5	-	35°
8102 200 012	20	12	1,5	-	35°
8102 250 012	24,7	12	1,5	-	35°
8102 300 012	30	12	1,5	14	35°
8102 400 012	40	12	1,5	26	35°
8102 500 012	50	12	1,5	26	35°
8102 600 012	60	12	1,5	26	35°

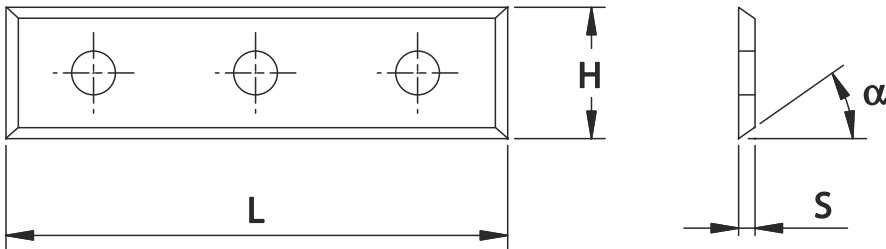
8162**HM: JİLET BIÇAKLAR**

- * Sunta-lam ve Mdf-lam Paneller İçin
- * 4 Keskin Kenar

KOD.	L	H	S	Açı	
8162 500 017	50	12	1,7	35°	Standart Kalite
8162 501 017	50	12	1,7	35°	Sert Kalite

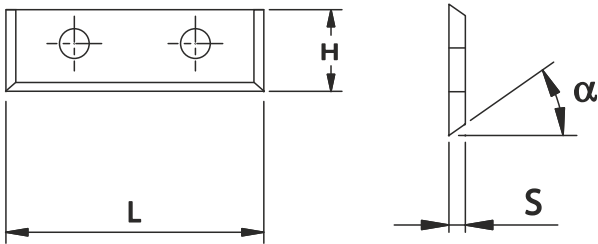
8150**HM: JİLET BIÇAKLAR**

- * Sunta-lam ve Mdf-lam Paneller İçin
- * 3 Keskin Kenar

KOD.	L	H	S	Açı
8150 280 007	28	7	1,5	35°

8105

HM: STANDART SERT METAL JİLET BİÇAKLAR

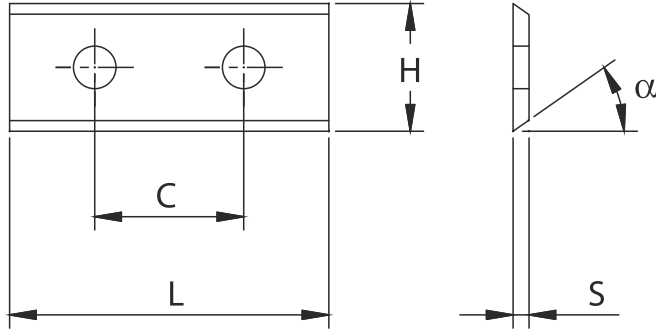

- * Standart Kalite
- Genel Amaçlı Kullanım
- * 2 Keskin Kenar

KOD.	L	H	S	C	Açı
8105 076 012	7,65	12	1,5	-	35°
8105 096 012	9,6	12	1,5	-	35°
8105 120 012	12	12	1,5	-	35°
8105 150 012	15	12	1,5	-	35°
8105 200 012	20	12	1,5	-	35°
8105 250 012	24,7	12	1,5	-	35°
8105 300 012	30	12	1,5	14	35°
8105 400 012	40	12	1,5	26	35°
8105 500 012	50	12	1,5	26	35°
8105 600 012	60	12	1,5	26	35°

8120

HM: SERT METAL JİLET BİÇAKLAR

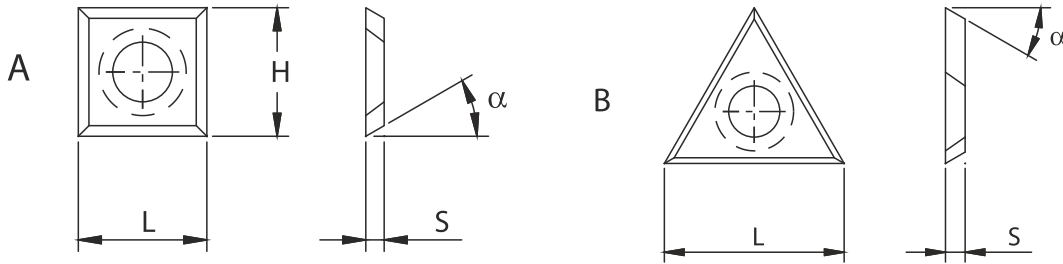

KOD.	L	H	S	Açı	Tip
8120 140 001	14	14	1,2	30°	A
8120 140 002	14	14	2,0	30°	A
8120 140 003	14,2	14,2	2,5	30°	A
8120 150 001	15	15	2,5	30°	A
8120 170 001	17	17	2,0	30°	A
8120 228 003	22	-	2,0	30°	B
8120 228 004	22	-	2,5	30°	B

8115

HM: SERT METAL JİLET BİÇAKLAR

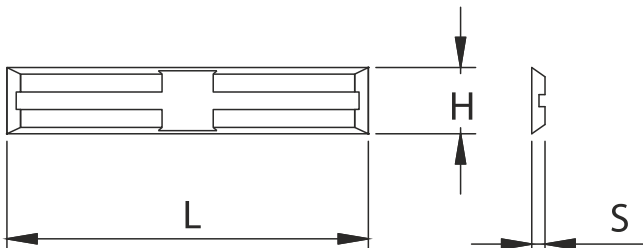

KOD.	L	H	S
8115 200 041	20	4,1	1,1
8115 200 055	20	5,5	1,1
8115 250 055	25	5,5	1,1
8115 300 055	30	5,5	1,1
8115 400 055	40	5,5	1,1
8115 500 055	50	5,5	1,1
8115 820 055	82	5,5	1,1

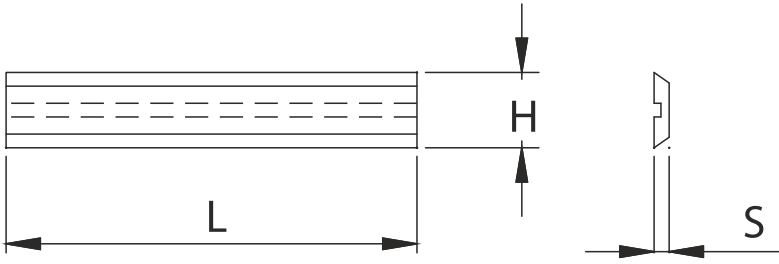
8114**HM: SERT METAL JİLET BIÇAKLAR**

KOD.	L	H	S
8114 077 080	7,7	8	1,5
8114 097 080	9,7	8	1,5
8114 117 080	11,7	8	1,5
8114 147 080	14,7	8	1,5
8114 197 080	19,7	8	1,5
8114 250 080	25	8	1,5
8114 300 080	30	8	1,5
8114 400 080	40	8	1,5
8114 450 080	45	8	1,5
8114 500 080	50	8	1,5
8114 600 080	60	8	1,5
8114 800 080	80	8	1,5
8114 100 080	100	8	1,5

8212**HM: SERT METAL JİLET BIÇAKLAR**

KOD.	L	H	S	R	TİP
8212 012 010	12,7	12,7	3,18	1	A
8212 012 015	12,7	12,7	3,18	1,5	A
8212 012 020	12,7	12,7	3,18	2	A
8212 012 030	12,7	12,7	3,18	3	A
8212 034 001	34	12,7	3	1/2/3	B
8212 034 002	34	12,7	3	1,5/2/3	B
8212 020 010	20	12	2	1	C
8212 020 015	20	12	2	1,5	C
8212 020 020	20	12	2	2	C
8212 020 030	20	12	2	3	C
8212 021 010	20	12	2	1	D
8212 021 015	20	12	2	1,5	D
8212 021 020	20	12	2	2	D
8212 021 030	20	12	2	3	D

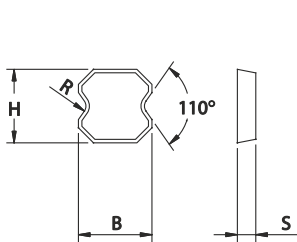
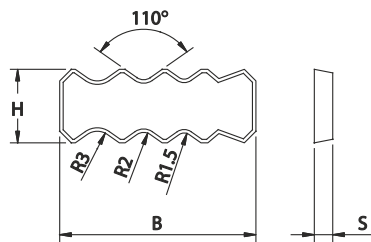
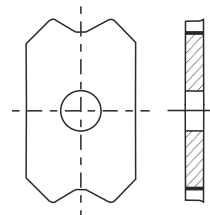
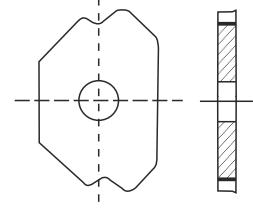
**A****B****C****D**

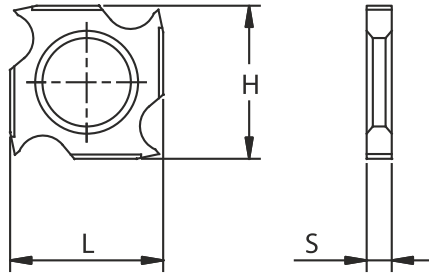
8125**HM: SERT METAL JİLET BIÇAKLAR**

KOD.	L	H	S
8125 180 019	18	18	1,95
8125 180 025	18	18	2,50
8125 180 029	18	18	2,95
8125 180 037	18	18	3,70
8125 180 040	18	18	4,00

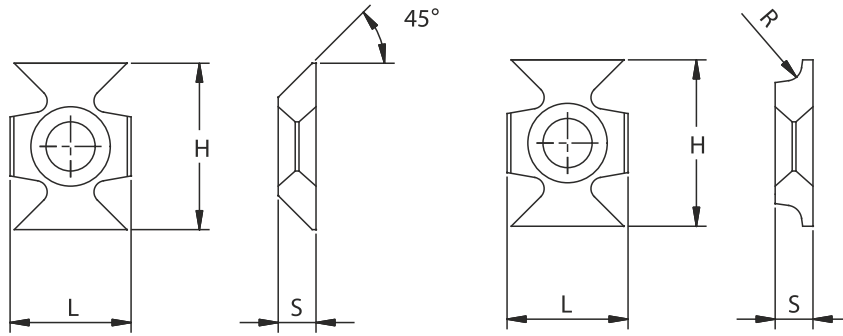
8130**HM: SERT METAL JİLET BIÇAKLAR**

KOD.	L	H	S	R	a
8130 220 045	16	22	5	-	45°
8130 220 015	16	22	5	1,5	-
8130 220 020	16	22	5	2	-
8130 220 030	16	22	5	3	-
8130 220 040	16	22	5	4	-
8130 220 050	16	22	5	5	-

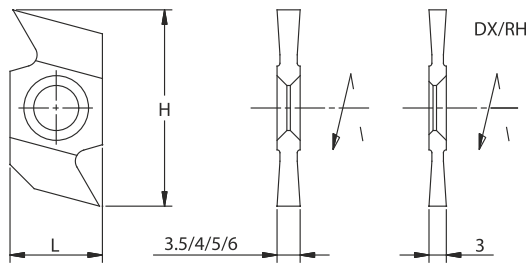
8140**HM: SERT METAL JİLET BIÇAKLAR**

KOD.	L	H	S
8140 030 000	16	34	3
8140 035 000	16	34	3,5
8140 040 000	16	34	4
8140 050 000	16	34	5
8140 060 000	16	34	6

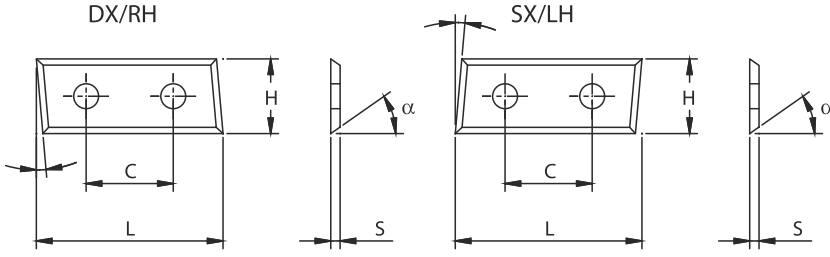
8145-8146**HM: SERT METAL JİLET BIÇAKLAR**

* Standart Kalite
Genel Amaçlı Kullanım

* Mikron Kalite
Sunta-lam ve Mdf-lam Paneller İçin
* 4 Keskin Kenar

KOD. RH.	KOD. LH.	L	H	S	C	Açı	Kalite
8145 300 012	8146 300 012	30	12	1,5	14	35°	Standart
8145 301 012	8146 301 012	30	12	1,5	14	35°	Sert
8145 500 012	8146 500 012	50	12	1,5	26	35°	Standart
8145 501 012	8146 501 012	50	12	1,5	26	35°	Sert
8145 600 012	8146 600 012	60	12	1,5	26	35°	Standart
8145 601 012	8146 601 012	60	12	1,5	26	35°	Sert

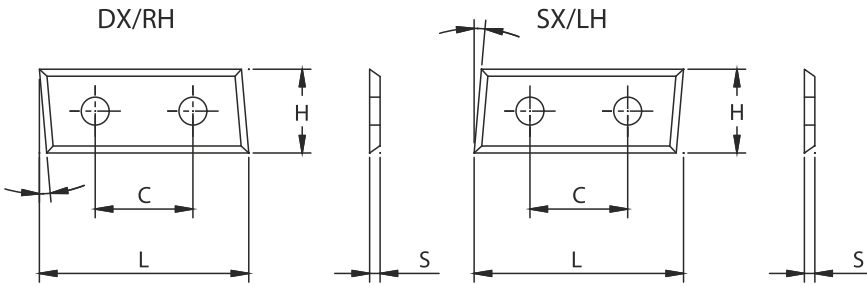
8150-8151**HM: SERT METAL JİLET BIÇAKLAR**

* 4 Keskin Kenar

KOD. RH.	KOD. LH.	L	H	S	C	Açı
8150 300 009	8151 300 009	30	9	1,5	14	35°
8150 400 009	8151 400 009	40	9	1,5	26	35°
8150 500 009	8151 500 009	50	9	1,5	26	35°

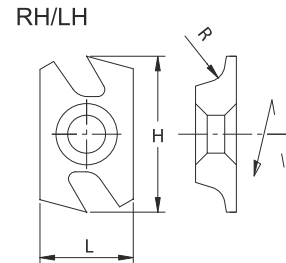
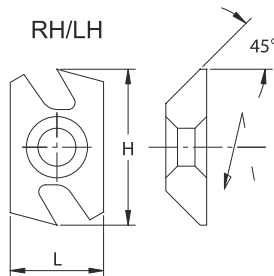
8131-8132**HM: JİLET BIÇAKLAR**

KOD. RH.	KOD. LH.	L	H	S	R	Açı
8131 260 045	8132 260 045	16	26,74	7	-	45°
8131 260 015	8132 260 015	16	26,74	7	1,5	-
8131 260 020	8132 260 020	16	26,74	7	2	-
8131 260 030	8132 260 030	16	26,74	7	3	-
8131 260 050	8132 260 050	16	26,74	7	5	-

AH757

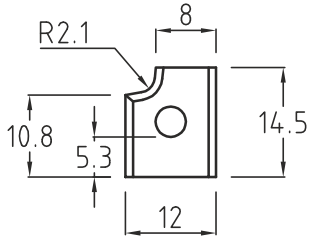

AH757-1

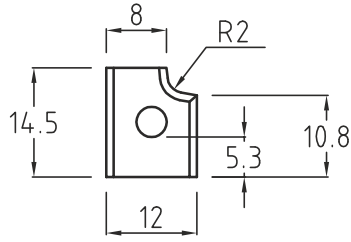

AG803

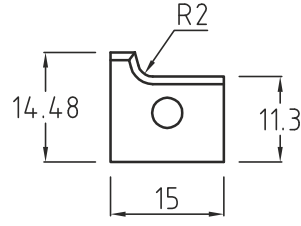

AG803-1

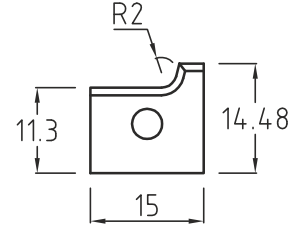

KOD.	L	H	S	R
8170 015 012 AH757	14,5	12	2	2
8170 015 012 AH757-1	14,5	12	2	2
8209 020 003 AG803	15	14,48	2	2
8209 020 004 AG803-1	15	14,48	2	2

AG802

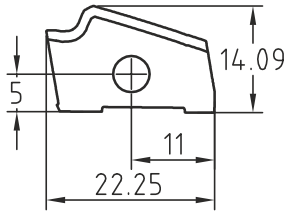

AG802-1

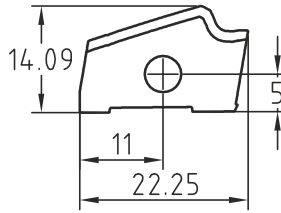

AG800

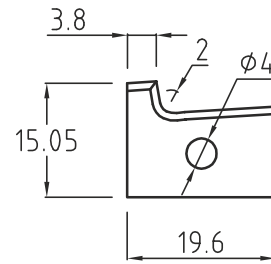

AG800-1

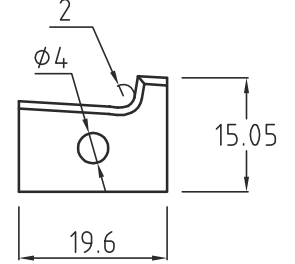

KOD.	L	H	S	R
8209 020 001 AG802	22,25	14,09	2	2
8209 020 002 AG802-1	22,25	14,09	2	2
8209 020 007 AG800	19,6	15,05	2	2
8209 020 008 AG800-1	19,6	15,05	2	2

AP779

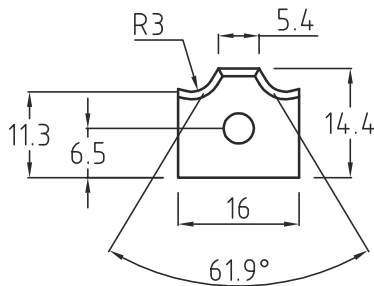

AP780

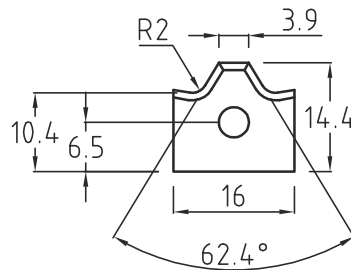

AH515

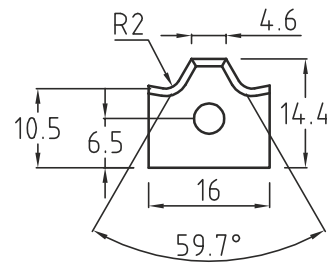

AG184

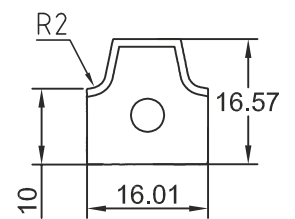

KOD.	L	H	S	R
8170 016 020 AP779	16	14,4	2	3
8170 016 020 AP780	16	14,4	2	2
8205 120 000/63 AH515	16	14,4	2	2
8205 020 000 AG184	16	16,5	2	2

AN764

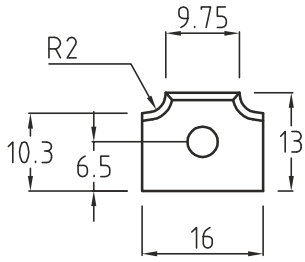

SF456 -1

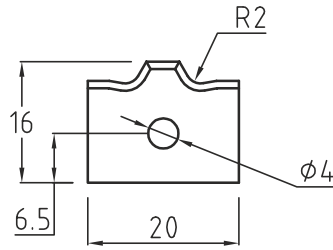

AF223

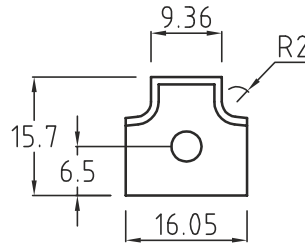

AN762

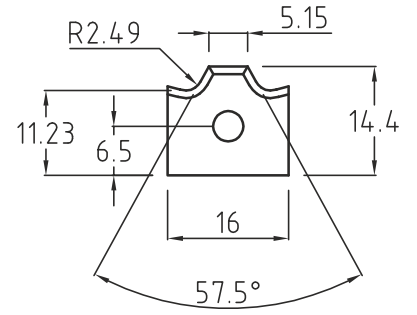

KOD.	L	H	S	R
8170 016 013 AN764	16	13	2	2
8210 020 000 SF461-1	20	16	2	2
8205 120 000 AF223	16,05	15,7	2	2
8170 016 014 AN762	16	14,4	2	2

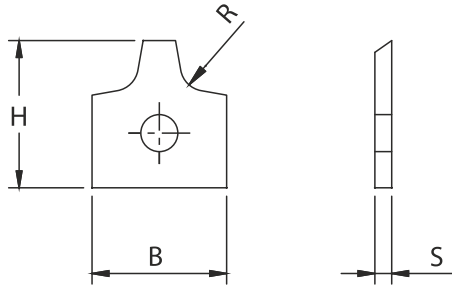

AG804

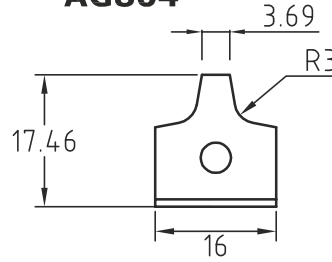

AG805

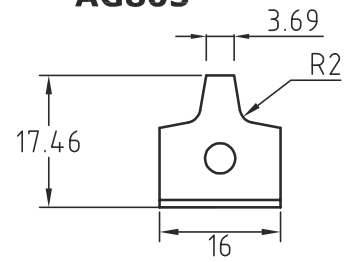

KOD.	L	H	S	R
8205 010 000	16	17,5	2	1
8205 020 000 AG805	16	17,5	2	2
8205 030 000 AG804	16	17,5	2	3
8205 110 000	16	16,5	2	1
8205 120 000	16	16,5	2	2
8205 130 000	16	16,5	2	3

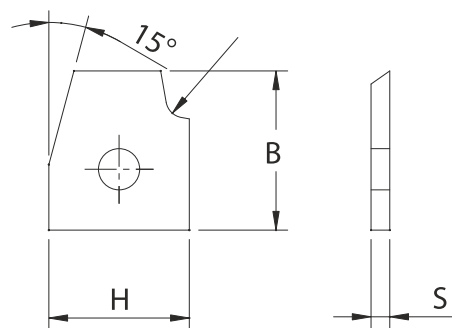
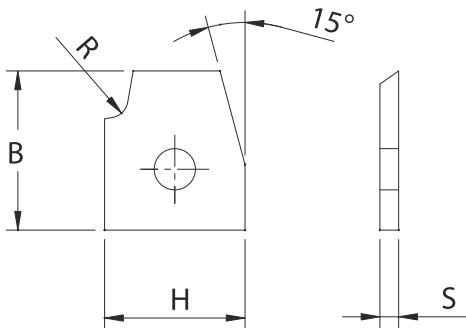

KOD.	L	H	S	R
8213 020 001	15	16	2	2
8213 020 002	15	16	2	2
8213 030 001	15	16	2	3
8213 030 002	15	16	2	3

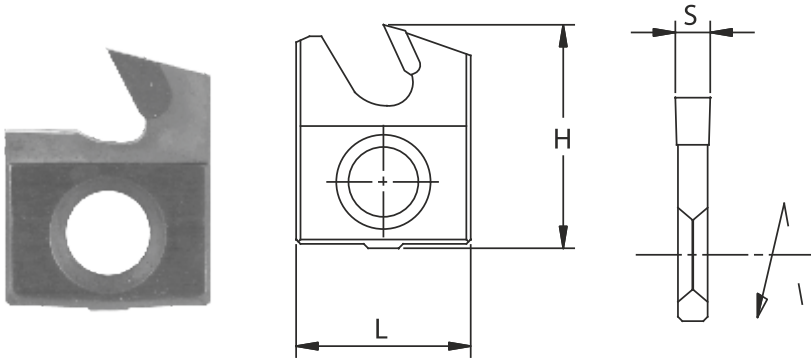
8142**HM: SERT METAL JİLET BIÇAKLAR**

KOD.	L	H	S
8142 030 025	20	25,6	3
8142 030 035	20	35,6	3
8142 040 025	20	25,6	4
8142 040 035	20	35,6	4
8142 050 025	20	25,6	5
8142 050 035	20	35,6	5
8142 060 025	20	25,6	6
8142 060 035	20	35,6	6

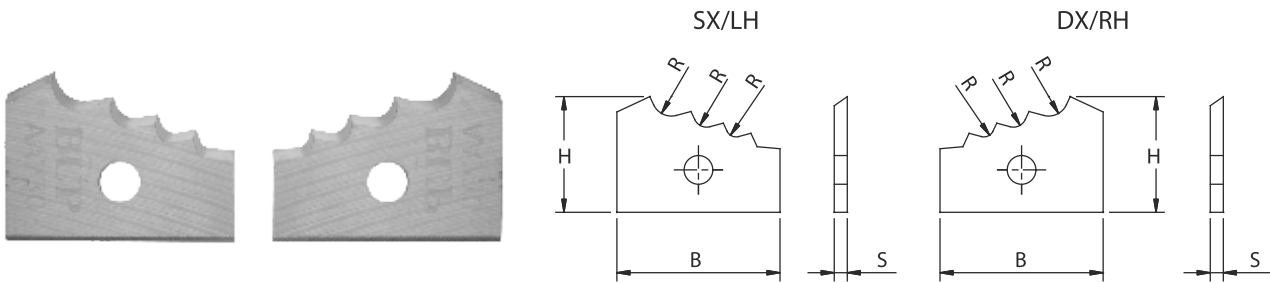
8208**HM: SERT METAL JİLET BIÇAKLAR**

KOD. RH	KOD. LH	B	H	S	R
8208 000 001	8208 000 002	25	19	2	1/1,5/2
8208 000 003	8208 000 004	25	19	2	1,5/2/3

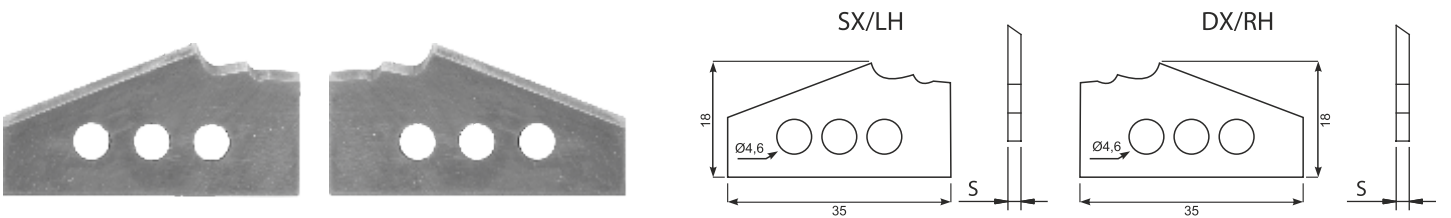
8209**HM: SERT METAL JİLET BIÇAKLAR**

KOD. RH	KOD. LH	B	H	S	R
8209 000 001	8209 000 002	35	18	2	1/1,5
8209 000 003	8209 000 004	35	18	2	1,5/2
8209 000 005	8209 000 006	35	18	2	2/3

Matkap Uçları

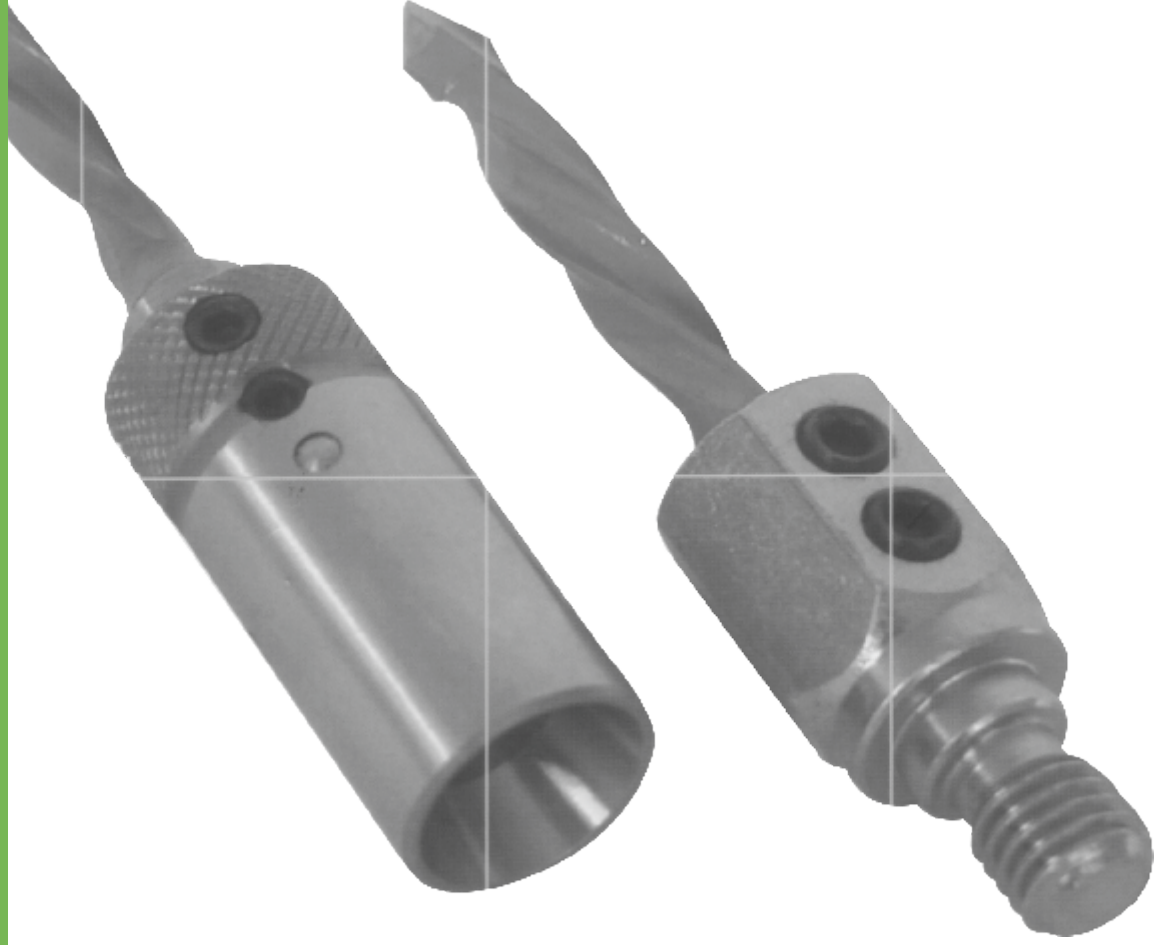



BUP[®]
UTENSILI

7045-7046

BUP M8 MATKAP ADAPTÖRLERİ

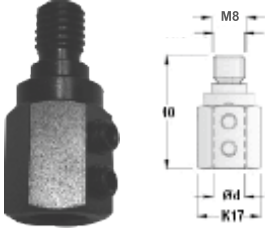
Masterwood, Morbidelli



SAĞ / RH	SOL / LH	Ød mm	D	L	
7045 100 041	7046 100 041	10	19,5	40	M8

7035-7036

BUP M10 MATKAP ADAPTÖRLERİ

Biesse, Masterwood, Weeke, Morbidelli

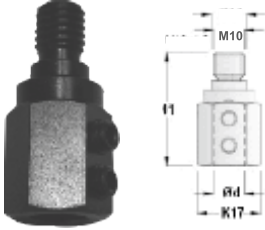

SAĞ / RH	SOL / LH	Ød mm	D	L	
7035 100 041	7036 100 041	10	19,5	41	M10

7027

BUP QUICK CHANGE MATKAP ADAPTÖRLERİ

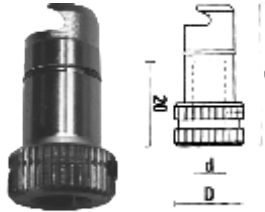

SAĞ / RH	SOL / LH	Ød mm	D	L	
7027 100 000	7027 100 000	10	20	37	Biesse Techno

7028

BUP QUICK CHANGE MATKAP ADAPTÖRLERİ

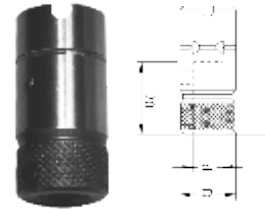

SAĞ / RH	SOL / LH	Ød mm	D	L	
7028 100 000	7028 100 000	10	20	43	Morbidelli

7029

BUP QUICK CHANGE MATKAP ADAPTÖRLERİ

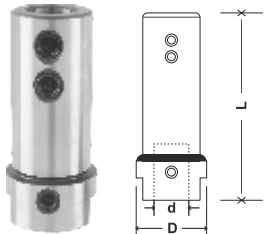

SAĞ / RH	SOL / LH	Ød mm	D	L	
7030 100 000	7030 100 000	10	20	46	Homag

7030

BUP QUICK CHANGE MATKAP ADAPTÖRLERİ

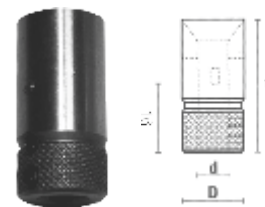

SAĞ / RH	SOL / LH	Ød mm	D	L	
7030 100 000	7030 100 000	10	18	42	Vitap
7029 100 001	7029 100 001	10	20	40	Maggi

7065-7066

HM: YARIM DELİK - DÜBEL MATKAPLARI (KISA)

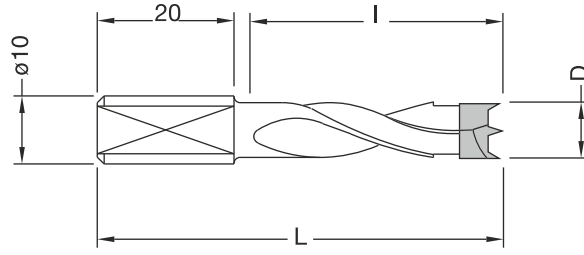

* RPM: 3000-6000
* İlerleme: 1/4 mt/dk.

KOD. RH	KOD. LH	D	I	L
7065 040 057	7066 040 057	4	30	57,5
7065 050 057	7066 050 057	5	30	57,5
7065 060 057	7066 060 057	6	30	57,5
7065 070 057	7066 070 057	7	30	57,5
7065 080 057	7066 080 057	8	30	57,5
7065 090 057	7066 090 057	9	30	57,5
7065 100 057	7066 100 057	10	30	57,5
7065 120 057	7066 120 057	12	30	57,5

7070-7071

HM: YARIM DELİK - DÜBEL MATKAPLARI (UZUN)

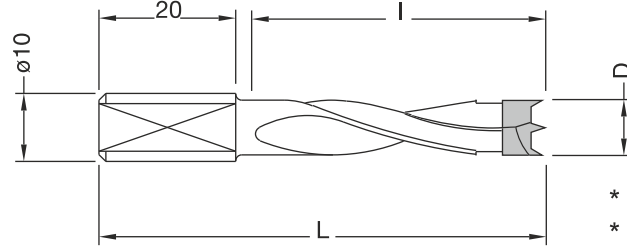

* RPM: 3000-6000
* İlerleme: 1/4 mt/dk.

KOD. RH	KOD. LH	D	I	L
7070 040 070	7071 040 070	4	43	70
7070 050 070	7071 050 070	5	43	70
7070 060 070	7071 060 070	6	43	70
7070 070 070	7071 070 070	7	43	70
7070 080 070	7071 080 070	8	43	70
7070 090 070	7071 090 070	9	43	70
7070 100 070	7071 100 070	10	43	70
7070 120 070	7071 120 070	12	43	70

7157-7158

HM: YARIM DELİK - SOLID DÜBEL MATKAPLARI (KISA)

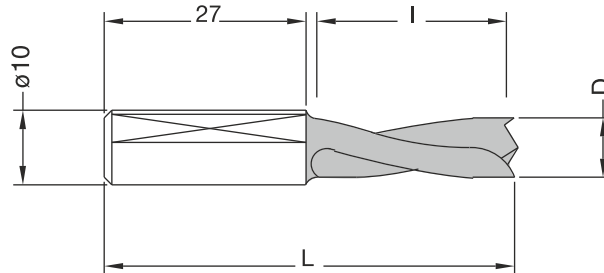

* RPM: 3000-6000
* İlerleme: 1/4 mt/dk.
* Yüksek Performans



KOD. RH	KOD. LH	D	I	L
7157 050 057	7158 050 057	5	27	57,5
7157 060 057	7158 060 057	6	27	57,5
7157 080 057	7158 080 057	8	27	57,5
7157 100 057	7158 100 057	10	27	57,5

7162-7163

HM: YARIM DELİK - SOLID DÜBEL MATKAPLARI (UZUN)

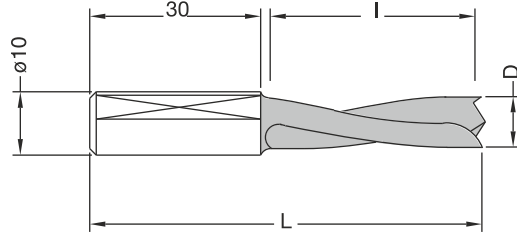

* RPM: 3000-6000
* İlerleme: 1/4 mt/dk.
* Yüksek Performans

KOD. RH	KOD. LH	D	I	L
7162 050 070	7163 050 070	5	35	70
7162 060 070	7163 060 070	6	35	70
7162 080 070	7163 080 070	8	35	70
7162 100 070	7163 100 070	10	35	70

7080-7081

HM: TAM DELİK MATKAPLAR (UZUN)

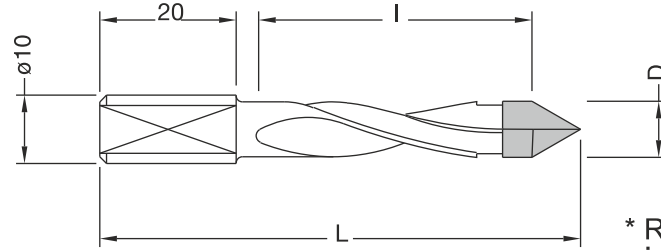

* RPM: 3000-6000
* İlerleme: 1/2,5 mt/dk.

KOD. RH	KOD. LH	D	I	L
7080 040 070	7081 040 070	4	35	70
7080 050 070	7081 050 070	5	40	70
7080 060 070	7081 060 070	6	40	70
7080 070 070	7081 070 070	7	40	70
7080 080 070	7081 080 070	8	40	70
7080 090 070	7081 090 070	9	40	70
7080 100 070	7081 100 070	10	40	70
7080 110 070	7081 110 070	11	40	70
7080 120 070	7081 120 070	12	40	70

7182-7183

HM: TAM DELİK SOLID MATKAPLAR (UZUN)

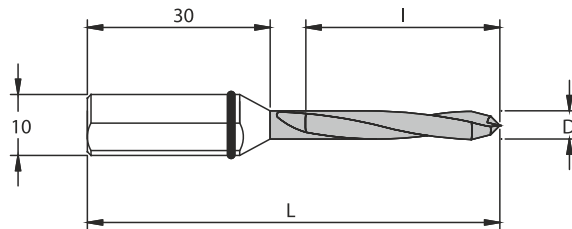

* RPM: 4000-8000
* İlerleme: 1/6,5 mt/dk.
* Yüksek Performans

KOD. RH	KOD. LH	D	I	L
7182 050 070	7183 050 070	5	43	70
7182 060 070	7183 060 070	6	43	70
7182 080 070	7183 080 070	8	43	70
7182 100 070	7183 100 070	10	43	70

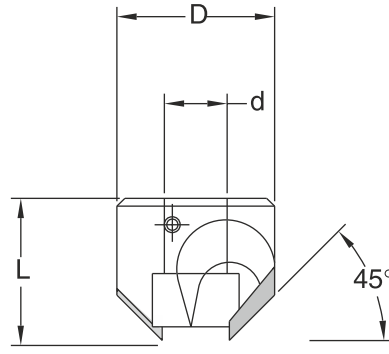
7095-7096**HM: HAVŞA MATKAPLARI**

* 7065 - 7070 - 7075 - 7080 Matkaplarda Kullanılır.

KOD. RH	KOD. LH	d	D	L
7095 040 160	7096 040 160	4	14	12
7095 050 160	7096 050 160	5	14	12
7095 060 160	7096 060 160	6	16	14
7095 070 160	7096 070 160	7	16	14
7095 080 180	7096 080 180	8	16	16
7095 090 180	7096 090 180	9	18	16
7095 100 200	7096 100 200	10	20	18

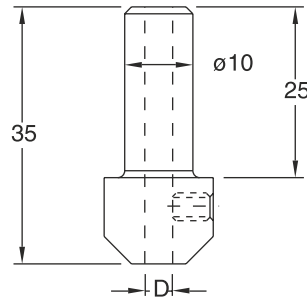
7118**HM: MATKAP KOVANLARI**

* 7125 - 7126 Matkaplarda Kullanılır.

KOD.	D	L
7118 020 000	2	35
7118 025 000	2,5	35
7118 030 000	3	35
7118 035 000	3,5	35
7118 040 000	4	35

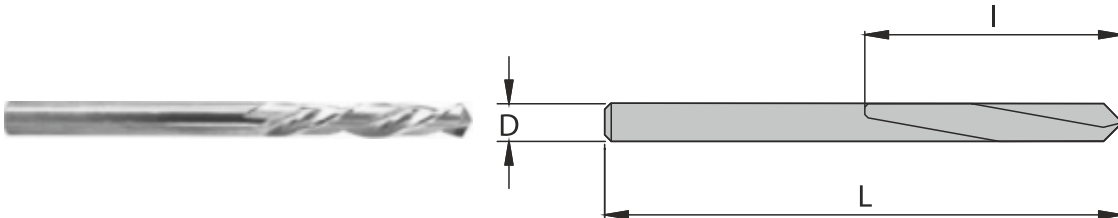
7125-7126**HM: SOLİD SERT METAL MATKAPLAR**

* RPM: 3000-8000
* İlerleme: 1/4 mt/dk.

KOD. RH.	KOD. LH.	D	L
7125 020 056	7126 020 056	2	49
7125 025 056	7126 025 056	2,5	55
7125 030 056	7126 030 056	3	55
7125 035 056	7126 035 056	3,5	55
7125 040 056	7126 040 056	4	55

7150-7151

HM: MENTEŞE MATKAPLARI (KISA)

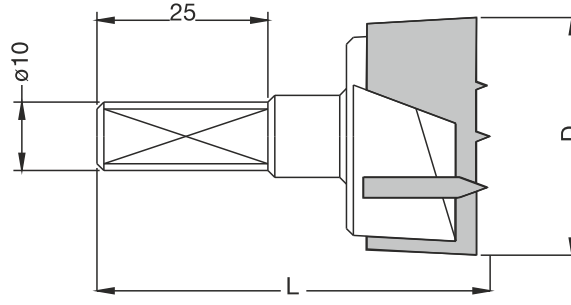
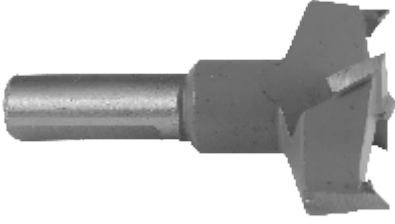

- * Minifix ve Menteşe Delikleri
- * RPM: 3000-6000
- * İlerleme: 1/2,5 mt/dk.

KOD. RH	KOD. LH	D	L
7150 150 057	7151 150 057	15	57,5
7150 160 057	7151 160 057	16	57,5
7150 180 057	7151 180 057	18	57,5
7150 200 057	7151 200 057	20	57,5
7150 220 057	7151 220 057	22	57,5
7150 240 057	7151 240 057	24	57,5
7150 250 057	7151 250 057	25	57,5
7150 260 057	7151 260 057	26	57,5
7150 280 057	7151 280 057	28	57,5
7150 300 057	7151 300 057	30	57,5
7150 320 057	7151 320 057	32	57,5
7150 350 057	7151 350 057	35	57,5

7150-7151

HM: MENTEŞE MATKAPLARI (UZUN)

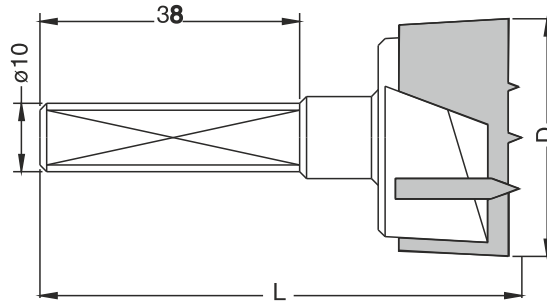
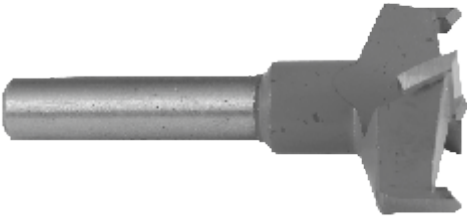

- * Minifix ve Menteşe Delikleri
- * RPM: 3000-6000
- * İlerleme: 1/2,5 mt/dk.

KOD. RH	KOD. LH	D	L
7150 150 070	7151 150 070	15	70
7150 160 070	7151 160 070	16	70
7150 180 070	7151 180 070	18	70
7150 200 070	7151 200 070	20	70
7150 220 070	7151 220 070	24	70
7150 250 070	7151 250 070	25	70
7150 260 070	7151 260 070	26	70
7150 280 070	7151 280 070	28	70
7150 300 070	7151 300 070	30	70
7150 320 070	7151 320 070	32	70
7150 350 070	7151 350 070	35	70

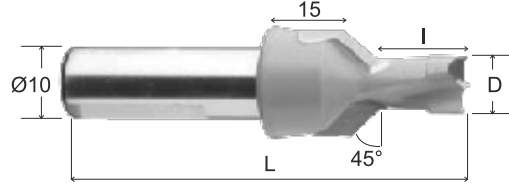
7135-7136**HM: HAVŞALI DÜBEL MATKAPLARI**

* Kendinden havşalı dübel matkabı
* Z 2+2 V2

KOD. RH	KOD. LH	D	I	L	S
7135 080 012	7136 080 012	8	12	57,5	10
7135 080 020	7136 080 020	8	20	57,5	10
7135 100 012	7136 100 012	10	12	57,5	10
7135 100 020	7136 100 020	10	20	57,5	10
7135 080 112	7136 080 112	8	12	70	10
7135 080 120	7136 080 120	8	20	70	10
7135 100 112	7136 100 112	10	12	70	10
7135 100 120	7136 100 120	10	20	70	10

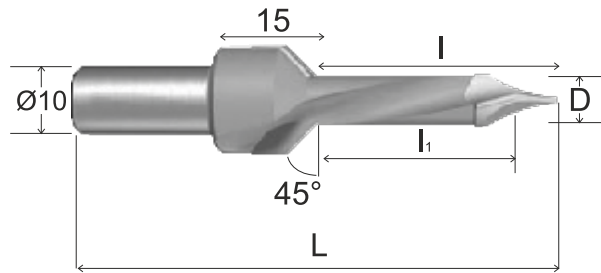
7137-7138**HM: HAVŞALI TAM DELİK MATKAPLARI**

* Kendinden havşalı
tam delik matkabı
* Z2 V2

KOD. RH	KOD. LH	D	I	I ₁	L	S
7137 050 070	7138 050 070	5	35	31	70	10
7137 070 070	7138 070 070	7	35	29,5	70	10
7137 080 070	7138 080 070	8	35	29	70	10
7137 100 070	7138 100 070	10	35	26,5	70	10

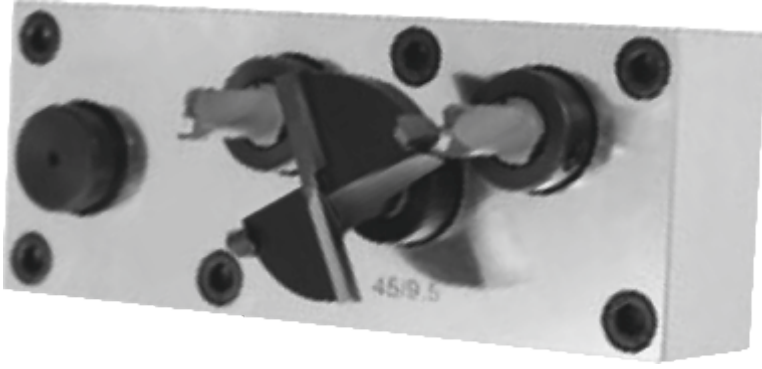

- * Blum, Salice, Hafele and Hettich Menteşeler için 45/9,5 ve 48/6
- * Delik makinaları ve CNC makina delik işlemleri için yardımcı delik ünitesi

KOD.	D	L	AÇIKLAMA
7139 000 000	Delik Aparatı (Matkap uçları hariç)	-	45/9,5
7139 000 001	Delik Aparatı (Matkap uçları hariç)	-	48/6
7150 350 385	35	38,5	Sağ Dönüşlü
7066 080 385	8	38,5	Sol Dönüşlü

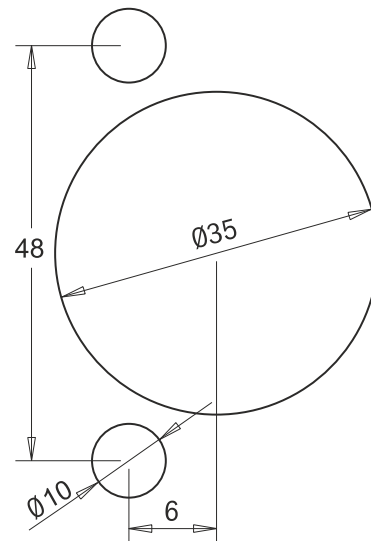
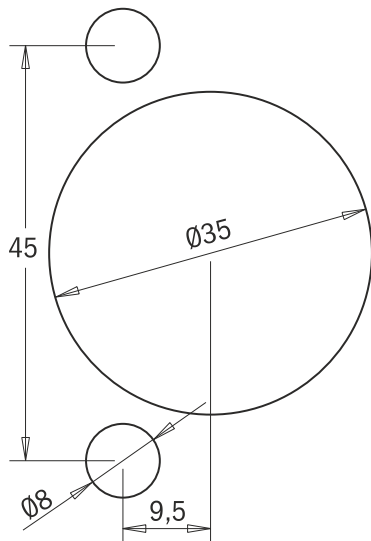
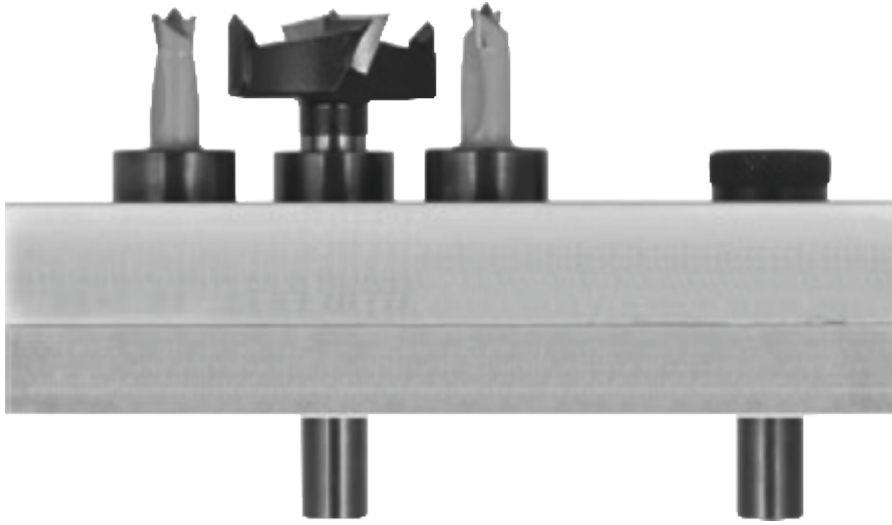

TAKIM ÖLÇÜM CİHAZI H300 mm - Ø 250 mm

- * Uygun fiyat ve kaliteli
- * Kolay kullanım özellikleri
- * Şaftlı ve delikli takımlar için uygun
- * Pille çalışabilir, elektrik gereksinimi yok
- * Geniş ekran
- * Değişebilir adaptörlü (ISO, HSK)

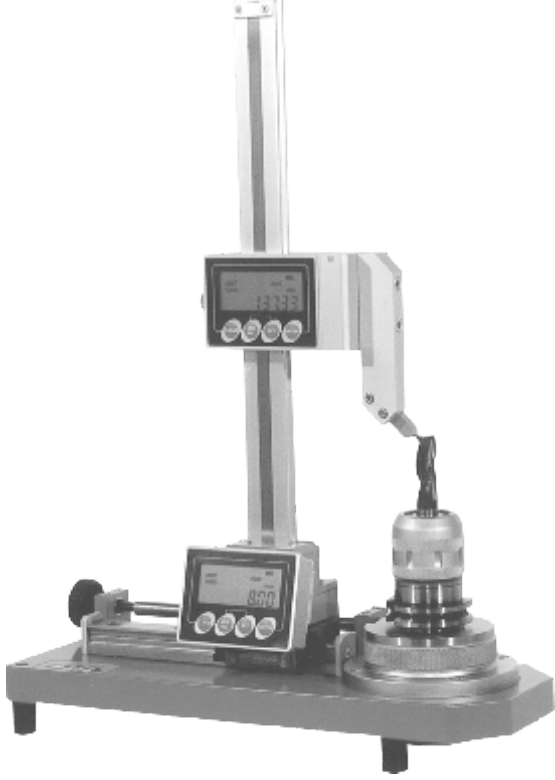

Boyutlar	Hassasiyet	Ağırlık	Güç
H: 540 mm B: 410 mm P: 150 mm	0,01 mm	12 kg	2 adet AA pil

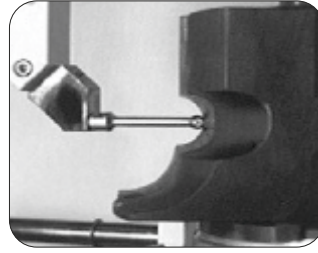

Opsiyonel Küre Uç



Opsiyonel Tutucular
(ISO30, ISO40, HSK63)

LINEER ÖLÇÜM CİHAZI

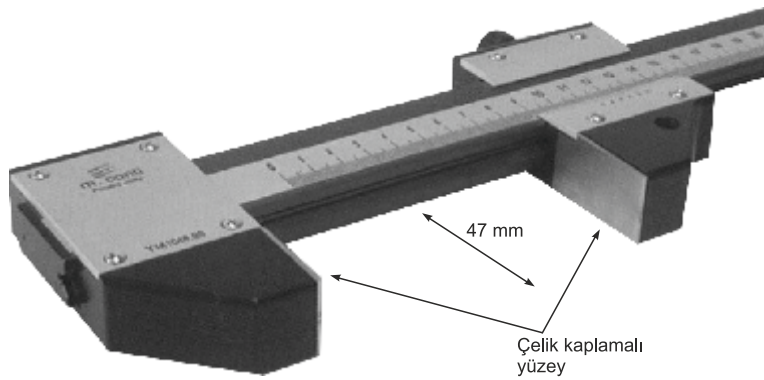

- * Ahşap panellerin genişlik ve uzunluk ölçümü için uygun
- * Cam, alüminyum ve metal malzemelerde de kullanılabilir
- * Çelik kaplamalı ölçüm ağızı

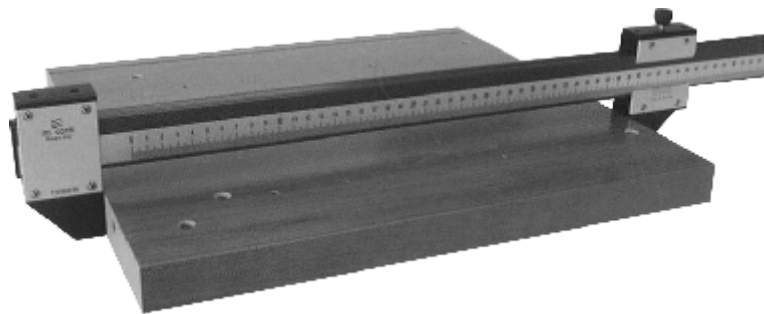

Boyutlar

0-500

0-750

0-1000

0-1500

0-2000

0-2500

0-3200



www.bup.com.tr



BUP®
KESİCİ TAKIMLAR

BUP Kesici Takımlar
Sanayi ve Ticaret Limited Şirketi
Yeni Çamlıca Mah. Yedpa İş Merk.
C Cad. No: 39 Ataşehir / İstanbul - TÜRKİYE
Tel.: +90 216 661 52 14 / 661 52 15
Fax : +90 216 661 51 65
www.bup.com.tr - info@bup.com.tr



Bilgilerimiz

BUP®
UTENSİLİ

BUP Utensili
61100 Pesaro • İtalya • Via Liguria, 15
Tel. (39)0721_453454 (4 linee r.a.)
Fax (39) 0721_455448
www.buputensili.it • info@buputensili.it



E-Katalog